

## General Description

The TMR6404X is a type of 4 channels magnetic pattern recognition sensor with high sensitivity, high signal-to-noise ratio performance, stable magnetization and detection for high coercive force magnetic materials, it is used for detecting paper bills, bank notes and security documents with magnetic anti-counterfeiting consists. TMR6404X covers wide detection width provides a low cost solution for scanning multiple currencies. The TMR6404X consists of high sensitivity TMR magneto-resistance sensor, high-quality magnet, high-strength plastic base and durable non-magnetic stainless steel cover.

## Features and Benefits

- Stable magnetization and detection for high coercive force magnetic materials
- High sensitivity and excellent gap performances
- Output voltage is independent of scanning speed
- Differential output, high CMRR performance
- Durable metal case, suitable for heavy load situations
- 10mm x 4ch detection width, no non-detection area
- Compact size: L 43.8mm x W 11.5mm x H 15.2mm

## Applications

- Bill counter and validator
- Bill sorter
- Magnetic ink document reader
- Vending machines

## Appearance



## Pin Configuration

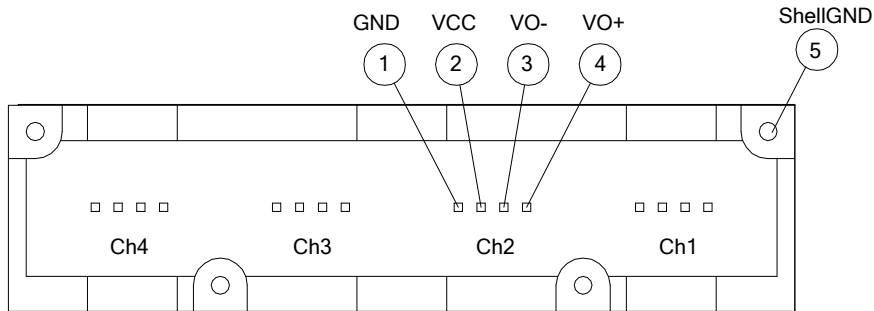

Bottom View

Pin No.	Symbol	Description
1	GND(n)	Ground of channel n
2	V <sub>CC</sub> (n)	Power Supply of channel n
3	V <sub>O+</sub> (n)	Positive output of channel n
4	V <sub>O-</sub> (n)	Negative output of channel n
5	Shell GND	Shell ground pin, connected to shielding ground

## Absolute Maximum Ratings

Parameter	Symbol	Rating	Unit
Maximum Supply Voltage	V <sub>CC</sub>	5.5	V
Operating Temperature	T <sub>A</sub>	-20 ~ 65	°C
Storage Temperature	T <sub>stg</sub>	-30 ~ 85	°C
Operating Humidity	HMD	10 ~ 90 (no dew)	%RH
ESD (HBM)	V <sub>HBM</sub>	2000	V

## Electrical & Physical Characteristics (V<sub>CC</sub>=5V, T<sub>A</sub>=25°C)

Parameter	Symbol	Conditions	Min	Typ	Max	Unit
Sensitivity	S <sup>(1)</sup>			TBD		V
Resistance Per Channel	R	No external magnetic field	0.5		5	kOhm
Output Offset Voltage	V <sub>OS</sub>	No external magnetic field	-75		75	mV/V
Noise	V <sub>N</sub> <sup>(2)</sup>			50		μVpp
Surface Magnetic Field	B			2000		G
Sensitivity Deviation	ΔS	S <sub>MAX</sub> / S <sub>MIN</sub>	1		2	V/V
Number of Channels	C			4		
Detecting Width	W			10		mm

### Notes:

(1) According to the MultiDimension sensitivity measurement.

(2) The amplifier's gain is 80dB@1kHz, no external magnetic field applied, measure the peak-to-peak voltage V<sub>PP</sub>, then V<sub>N</sub> = V<sub>PP</sub>/10000.

## Caution for Use

- The sensor contains a permanent magnet, it will cause the recordable magnetic media damaged, such as cassette tapes, floppy disks, credit cards, hard drives, keep it away from such types of magnetic media.
- To avoid the ferromagnetic particles being collected from a dirty environment.
- Magnets tend to snap to each other or the magnetic metals, be careful when handling the sensor not to apply mechanical shock, otherwise the sensors might be abnormal or break.
- Do not place the sensor near the person who has an electronic medical device. It is very dangerous and may cause malfunction of an electronic medical device.
- Magnetic devices may be subject to special transport regulations.
- To avoid the abrasion of the sensor's metal case or stuck the banknote, about 0.1mm gap between the sensor and the opposite side such as rollers is recommended to reduce the pressure of the sensor's metal case.
- To avoid excessive force on terminals, please mount the sensor's base firmly on the PCB and solder all the terminals.
- Hand soldering should be applied, the soldering temperature should be  $350\pm 10^{\circ}\text{C}$  less than 3 seconds or  $260\pm 5^{\circ}\text{C}$  less than 10 seconds.

## Recommended Application Circuit

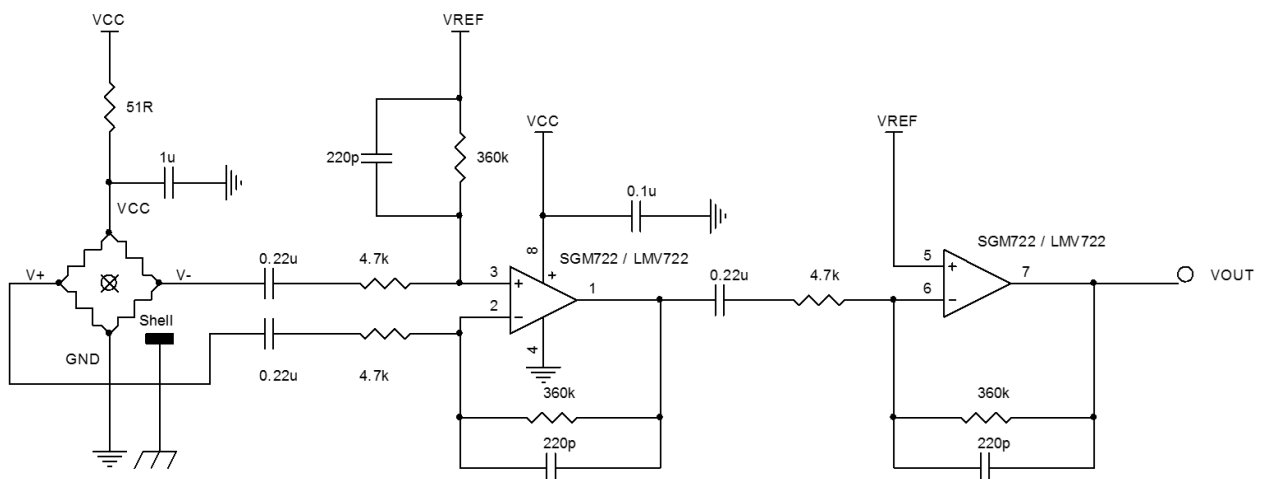

### Notes:

- (1) Shell GND pin should be connected to the equipment ground.

### Mechanical Drawings & Dimensions

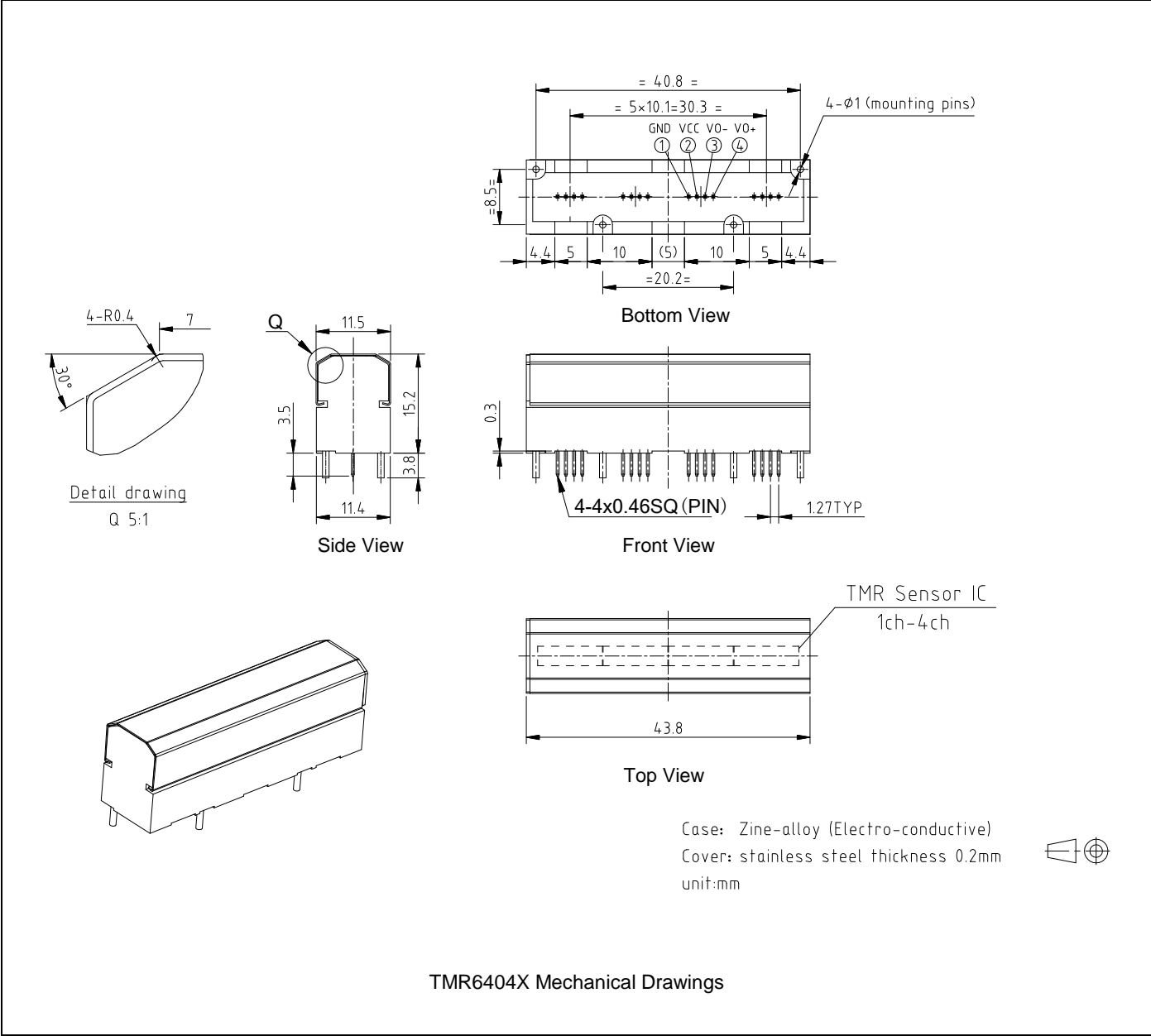



**MultiDimension Technology Co., Ltd.**

Address: No.7 Guangdong Road, Zhangjiagang Free Trade Zone, Jiangsu, 215634, China

Web: [www.dowaytech.com/en](http://www.dowaytech.com/en)

Email: [info@dowaytech.com](mailto:info@dowaytech.com)

The information provided herein by MultiDimension Technology Co., Ltd. (hereinafter MultiDimension) is believed to be accurate and reliable. Publication neither conveys nor implies any license under patent or other industrial or intellectual property rights. MultiDimension reserves the right to make changes to product specifications for the purpose of improving product quality, reliability, and functionality. MultiDimension does not assume any liability arising out of the application and use of its products. MultiDimension's customers using or selling this product for use in appliances, devices, or systems where malfunction can reasonably be expected to result in personal injury do so at their own risk and agree to fully indemnify MultiDimension for any damages resulting from such applications.