

TMR7303-D/P1

Unibody, Miniature Current Sensor

RoHS  CE

Description

TMR7303-D/P1 is based on tunnel magnetoresistance (TMR) technology with high signal-to-noise ratio (SNR) and high sensitivity for measuring DC, AC, pulsed current and arbitrary waveform current with galvanic isolation and its internal temperature compensation circuitry provides excellent performance under different ambient temperature ranges. It is also a open loop current sensor with low power, miniature size, excellent frequency response.

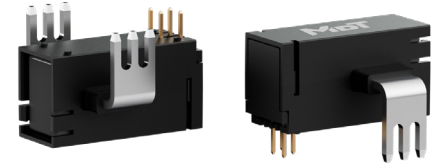

Features and Benefits

- Tunneling magnetoresistance (TMR) technology
- Fast response time, high bandwidth (≥ 500 kHz)
- Low noise, low power consumption
- Excellent temperature stability
- RoHS & REACH Compliant, UL Certified

Applications

- Photovoltaic inverter
- Switching power supplies
- Inverter and variable frequency drives (VFD)
- DC motor drive
- Power supplies for welding application

Selection Guide

Model	Primary Nominal Current	Primary Current Measuring Range
TMR7303-010D/P1	10 A	± 25 A
TMR7303-016D/P1	16 A	± 40 A
TMR7303-020D/P1	20 A	± 50 A
TMR7303-032D/P1	32 A	± 80 A
TMR7303-040D/P1	40 A	± 100 A
TMR7303-050D/P1	50 A	± 125 A
TMR7303-080D/P1	80 A	± 200 A
TMR7303-120D/P1	120 A	± 300 A

Insulation and Environmental Characteristics

Parameters	Symbol	Typical	Unit
Supply Voltage (absolute maximum)	V_{CC}	7	V
Dielectric Strength	V_D	4.3	kV(50Hz, 1min)
Creepage Distance (PCB installation)	d_{CP}	8	mm
Clearance (PCB installation)	d_{CL}	8	mm
ESD Performance (HBM)	V_{ESD}	4	kV
Ambient Operating Temperature	T_A	-40 to +105	$^{\circ}C$
Ambient Storage Temperature	T_{STG}	-40 to +105	$^{\circ}C$
Mass	m	6.5	g

Catalogue

1. TMR7303-010D/P1 Specifications	03
2. TMR7303-016D/P1 Specifications	04
3. TMR7303-020D/P1 Specifications	05
4. TMR7303-032D/P1 Specifications	06
5. TMR7303-040D/P1 Specifications	07
6. TMR7303-050D/P1 Specifications	08
7. TMR7303-080D/P1 Specifications	09
8. TMR7303-120D/P1 Specifications	10
9. Typical Output Characteristics.....	11
10. Frequency Response Characteristic	12
11. Parameters Definition and Formula	13
12. Dimensions	14
13. Pin Configuration and Wiring Diagram	14
14. Recommended PCB Layout.....	15
15. Remarks	15
16. Wave Soldering Temperature Curve.....	16
17. Packaging information.....	17

1. TMR7303-010D/P1 Specifications

$T_A = 25\text{ }^\circ\text{C}$, $V_{CC} = 5\text{ V}$, $R_L = 10\text{ k}\Omega$, unless otherwise noted

Parameter	Symbol	Conditions	Min.	Typ.	Max.	Unit
General Electrical Data						
Primary Nominal Current	I_{PN}	TMR7303-010D/P1	-	10	-	A
Primary Current Measuring Range	I_{PM}	TMR7303-010D/P1	-25	-	25	A
Sensitivity	S	TMR7303-010D/P1	-	80	-	mV/A
Reference Voltage Output	V_{REF}	$T_A = 25\text{ }^\circ\text{C}$	2.49	-	2.51	V
		$T_A = -40\text{ }^\circ\text{C to } +105\text{ }^\circ\text{C}$	2.48	-	2.52	
Output Voltage	V_{OUT}	$I_P = 0\text{ to } \pm I_{PM}$	-	$V_{REF} + 0.8 \times I_P/I_{PN}$	-	V
Supply Voltage	V_{CC}	$\pm 5\%$	4.75	5	5.25	V
Current Consumption	I_C	$I_P = 0$	-	3.5	4	mA
Power ON Time	t_{PO}	$V_{CC} \geq 2.5\text{ V}$	-	200	-	μs
Primary Conductor Input Resistance	R_{IN}	$T_A = 25\text{ }^\circ\text{C}$	-	0.1	-	m Ω
Output Impedance	R_{OUT}	-	-	2	5	Ω
Load Resistance	R_L	$I_P = 0\text{ to } \pm I_{PN}$	1	10	-	k Ω
Static Performance Data						
Accuracy	X_G	$T_A = 25\text{ }^\circ\text{C}$, $I_P = 0\text{ to } \pm I_{PN}$	-	± 1	-	% I_{PN}
		$T_A = -40\text{ }^\circ\text{C to } +105\text{ }^\circ\text{C}$, $I_P = 0\text{ to } \pm I_{PN}$	-4	± 3	4	
Linearity	ϵ_L	$I_P = 0\text{ to } \pm I_{PN}$	-	0.3	0.5	% I_{PN}
		$I_P = 0\text{ to } \pm I_{PM}$	-	0.5	0.8	% I_{PM}
Sensitivity Error	ϵ_S	$T_A = 25\text{ }^\circ\text{C}$, $I_P = 0\text{ to } \pm I_{PN}$	-1	-	1	%
		$T_A = -40\text{ }^\circ\text{C to } +105\text{ }^\circ\text{C}$, $I_P = 0\text{ to } \pm I_{PN}$	-1.5	-	1.5	
Offset Error	V_{OE}	$T_A = 25\text{ }^\circ\text{C}$, $I_P = 0$, $V_{OUT} - V_{REF}$	-5	-	5	mV
		$T_A = -40\text{ }^\circ\text{C} \sim +105\text{ }^\circ\text{C}$, $I_P = 0$, $V_{OUT} - V_{REF}$	-25	± 15	25	
Hysteresis	V_{OH}	$I_P = \pm I_{PM} \rightarrow 0$	-5	-	5	mV
Dynamic Performance Data						
Response Time	t_R	$di/dt > 100\text{ A}/\mu\text{s}$, 90% of V_{OUT} to 90% of I_{PN}	-	0.6	-	μs
Delay Time	t_D	500 kHz sine wave	-	0.5	-	μs
Bandwidth	BW	-3 dB	DC	500	-	kHz
Output Noise	V_N	DC to 10 kHz	-	10	-	mV _{pp}
		DC to 100 kHz	-	15	-	
		DC to 1 MHz	-	25	-	

2. TMR7303-016D/P1 Specifications

$T_A = 25\text{ }^\circ\text{C}$, $V_{CC} = 5\text{ V}$, $R_L = 10\text{ k}\Omega$, unless otherwise noted

Parameter	Symbol	Conditions	Min.	Typ.	Max.	Unit
General Electrical Data						
Primary Nominal Current	I_{PN}	TMR7303-016D/P1	-	16	-	A
Primary Current Measuring Range	I_{PM}	TMR7303-016D/P1	-40	-	40	A
Sensitivity	S	TMR7303-016D/P1	-	50	-	mV/A
Reference Voltage Output	V_{REF}	$T_A = 25\text{ }^\circ\text{C}$	2.49	-	2.51	V
		$T_A = -40\text{ }^\circ\text{C}$ to $+105\text{ }^\circ\text{C}$	2.48	-	2.52	
Output Voltage	V_{OUT}	$I_P = 0$ to $\pm I_{PM}$	-	$V_{REF} + 0.8 \times I_P/I_{PN}$	-	V
Supply Voltage	V_{CC}	$\pm 5\%$	4.75	5	5.25	V
Current Consumption	I_C	$I_P = 0$	-	3.5	4	mA
Power ON Time	t_{PO}	$V_{CC} \geq 2.5\text{ V}$	-	200	-	μs
Primary Conductor Input Resistance	R_{IN}	$T_A = 25\text{ }^\circ\text{C}$	-	0.1	-	m Ω
Output Impedance	R_{OUT}	-	-	2	5	Ω
Load Resistance	R_L	$I_P = 0$ to $\pm I_{PN}$	1	10	-	k Ω
Static Performance Data						
Accuracy	X_G	$T_A = 25\text{ }^\circ\text{C}$, $I_P = 0$ to $\pm I_{PN}$	-	± 1	-	% I_{PN}
		$T_A = -40\text{ }^\circ\text{C}$ to $+105\text{ }^\circ\text{C}$, $I_P = 0$ to $\pm I_{PN}$	-3.5	± 2	3.5	
Linearity	ε_L	$I_P = 0$ to $\pm I_{PN}$	-	0.3	0.5	% I_{PN}
		$I_P = 0$ to $\pm I_{PM}$	-	0.5	0.8	% I_{PM}
Sensitivity Error	ε_S	$T_A = 25\text{ }^\circ\text{C}$, $I_P = 0$ to $\pm I_{PN}$	-1	-	1	%
		$T_A = -40\text{ }^\circ\text{C}$ to $+105\text{ }^\circ\text{C}$, $I_P = 0$ to $\pm I_{PN}$	-1.5	-	1.5	
Offset Error	V_{OE}	$T_A = 25\text{ }^\circ\text{C}$, $I_P = 0$, $V_{OUT} - V_{REF}$	-5	-	5	mV
		$T_A = -40\text{ }^\circ\text{C}$ ~ $+105\text{ }^\circ\text{C}$, $I_P = 0$, $V_{OUT} - V_{REF}$	-20	± 12	20	
Hysteresis	V_{OH}	$I_P = \pm I_{PM} \rightarrow 0$	-5	-	5	mV
Dynamic Performance Data						
Response Time	t_R	$di/dt > 100\text{ A}/\mu\text{s}$, 90% of V_{OUT} to 90% of I_{PN}	-	0.5	-	μs
Delay Time	t_D	500 kHz sine wave	-	0.4	-	μs
Bandwidth	BW	-3 dB	DC	600	-	kHz
Output Noise	V_N	DC to 10 kHz	-	5	-	mV _{pp}
		DC to 100 kHz	-	15	-	
		DC to 1 MHz	-	20	-	

3. TMR7303-020D/P1 Specifications

$T_A = 25\text{ }^\circ\text{C}$, $V_{CC} = 5\text{ V}$, $R_L = 10\text{ k}\Omega$, unless otherwise noted

Parameter	Symbol	Conditions	Min.	Typ.	Max.	Unit
General Electrical Data						
Primary Nominal Current	I_{PN}	TMR7303-020D/P1	-	20	-	A
Primary Current Measuring Range	I_{PM}	TMR7303-020D/P1	-50	-	50	A
Sensitivity	S	TMR7303-020D/P1	-	40	-	mV/A
Reference Voltage Output	V_{REF}	$T_A = 25\text{ }^\circ\text{C}$	2.49	-	2.51	V
		$T_A = -40\text{ }^\circ\text{C}$ to $+105\text{ }^\circ\text{C}$	2.48	-	2.52	
Output Voltage	V_{OUT}	$I_P = 0$ to $\pm I_{PM}$	-	$V_{REF} + 0.8 \times I_P/I_{PN}$	-	V
Supply Voltage	V_{CC}	$\pm 5\%$	4.75	5	5.25	V
Current Consumption	I_C	$I_P = 0$	-	3.5	4	mA
Power ON Time	t_{PO}	$V_{CC} \geq 2.5\text{ V}$	-	200	-	μs
Primary Conductor Input Resistance	R_{IN}	$T_A = 25\text{ }^\circ\text{C}$	-	0.1	-	$\text{m}\Omega$
Output Impedance	R_{OUT}	-	-	2	5	Ω
Load Resistance	R_L	$I_P = 0$ to $\pm I_{PN}$	1	10	-	$\text{k}\Omega$
Static Performance Data						
Accuracy	X_G	$T_A = 25\text{ }^\circ\text{C}$, $I_P = 0$ to $\pm I_{PN}$	-	± 1	-	% I_{PN}
		$T_A = -40\text{ }^\circ\text{C}$ to $+105\text{ }^\circ\text{C}$, $I_P = 0$ to $\pm I_{PN}$	-3.5	± 2	3.5	
Linearity	ε_L	$I_P = 0$ to $\pm I_{PN}$	-	0.3	0.5	% I_{PN}
		$I_P = 0$ to $\pm I_{PM}$	-	0.5	1	% I_{PM}
Sensitivity Error	ε_S	$T_A = 25\text{ }^\circ\text{C}$, $I_P = 0$ to $\pm I_{PN}$	-1	-	1	%
		$T_A = -40\text{ }^\circ\text{C}$ to $+105\text{ }^\circ\text{C}$, $I_P = 0$ to $\pm I_{PN}$	-1.5	-	1.5	
Offset Error	V_{OE}	$T_A = 25\text{ }^\circ\text{C}$, $I_P = 0$, $V_{OUT} - V_{REF}$	-5	-	5	mV
		$T_A = -40\text{ }^\circ\text{C}$ ~ $+105\text{ }^\circ\text{C}$, $I_P = 0$, $V_{OUT} - V_{REF}$	-20	± 12	20	
Hysteresis	V_{OH}	$I_P = \pm I_{PM} \rightarrow 0$	-5	-	5	mV
Dynamic Performance Data						
Response Time	t_R	$di/dt > 100\text{ A}/\mu\text{s}$, 90% of V_{OUT} to 90% of I_{PN}	-	0.5	-	μs
Delay Time	t_D	500 kHz sine wave	-	0.4	-	μs
Bandwidth	BW	-3 dB	DC	600	-	kHz
Output Noise	V_N	DC to 10 kHz	-	5	-	mV_{PP}
		DC to 100 kHz	-	15	-	
		DC to 1 MHz	-	20	-	

4. TMR7303-032D/P1 Specifications

$T_A = 25\text{ }^\circ\text{C}$, $V_{CC} = 5\text{ V}$, $R_L = 10\text{ k}\Omega$, unless otherwise noted

Parameter	Symbol	Conditions	Min.	Typ.	Max.	Unit
General Electrical Data						
Primary Nominal Current	I_{PN}	TMR7303-032D/P1	-	32	-	A
Primary Current Measuring Range	I_{PM}	TMR7303-032D/P1	-80	-	80	A
Sensitivity	S	TMR7303-032D/P1	-	25	-	mV/A
Reference Voltage Output	V_{REF}	$T_A = 25\text{ }^\circ\text{C}$	2.49	-	2.51	V
		$T_A = -40\text{ }^\circ\text{C to } +105\text{ }^\circ\text{C}$	2.48	-	2.52	
Output Voltage	V_{OUT}	$I_P = 0\text{ to } \pm I_{PM}$	-	$V_{REF} + 0.8 \times I_P/I_{PN}$	-	V
Supply Voltage	V_{CC}	$\pm 5\%$	4.75	5	5.25	V
Current Consumption	I_C	$I_P = 0$	-	3.5	4	mA
Power ON Time	t_{PO}	$V_{CC} \geq 2.5\text{ V}$	-	200	-	μs
Primary Conductor Input Resistance	R_{IN}	$T_A = 25\text{ }^\circ\text{C}$	-	0.1	-	m Ω
Output Impedance	R_{OUT}	-	-	2	5	Ω
Load Resistance	R_L	$I_P = 0\text{ to } \pm I_{PN}$	1	10	-	k Ω
Static Performance Data						
Accuracy	X_G	$T_A = 25\text{ }^\circ\text{C}$, $I_P = 0\text{ to } \pm I_{PN}$	-	± 1	-	% I_{PN}
		$T_A = -40\text{ }^\circ\text{C to } +105\text{ }^\circ\text{C}$, $I_P = 0\text{ to } \pm I_{PN}$	-3	± 2	3	
Linearity	ε_L	$I_P = 0\text{ to } \pm I_{PN}$	-	0.5	1	% I_{PN}
		$I_P = 0\text{ to } \pm I_{PM}$	-	1	1.5	% I_{PM}
Sensitivity Error	ε_S	$T_A = 25\text{ }^\circ\text{C}$, $I_P = 0\text{ to } \pm I_{PN}$	-1	-	1	%
		$T_A = -40\text{ }^\circ\text{C to } +105\text{ }^\circ\text{C}$, $I_P = 0\text{ to } \pm I_{PN}$	-1.5	-	1.5	
Offset Error	V_{OE}	$T_A = 25\text{ }^\circ\text{C}$, $I_P = 0$, $V_{OUT} - V_{REF}$	-5	-	5	mV
		$T_A = -40\text{ }^\circ\text{C} \sim +105\text{ }^\circ\text{C}$, $I_P = 0$, $V_{OUT} - V_{REF}$	-20	± 12	20	
Hysteresis	V_{OH}	$I_P = \pm I_{PM} \rightarrow 0$	-5	-	5	mV
Dynamic Performance Data						
Response Time	t_R	$di/dt > 100\text{ A}/\mu\text{s}$, 90% of V_{OUT} to 90% of I_{PN}	-	0.5	-	μs
Delay Time	t_D	500 kHz sine wave	-	0.3	-	μs
Bandwidth	BW	-3 dB	DC	600	-	kHz
Output Noise	V_N	DC to 10 kHz	-	5	-	mV _{pp}
		DC to 100 kHz	-	15	-	
		DC to 1 MHz	-	20	-	

5. TMR7303-040D/P1 Specifications

$T_A = 25\text{ }^\circ\text{C}$, $V_{CC} = 5\text{ V}$, $R_L = 10\text{ k}\Omega$, unless otherwise noted

Parameter	Symbol	Conditions	Min.	Typ.	Max.	Unit
General Electrical Data						
Primary Nominal Current	I_{PN}	TMR7303-040D/P1	-	40	-	A
Primary Current Measuring Range	I_{PM}	TMR7303-040D/P1	-100	-	100	A
Sensitivity	S	TMR7303-040D/P1	-	20	-	mV/A
Reference Voltage Output	V_{REF}	$T_A = 25\text{ }^\circ\text{C}$	2.49	-	2.51	V
		$T_A = -40\text{ }^\circ\text{C}$ to $+105\text{ }^\circ\text{C}$	2.48	-	2.52	
Output Voltage	V_{OUT}	$I_P = 0$ to $\pm I_{PM}$	-	$V_{REF} + 0.8 \times I_P/I_{PN}$	-	V
Supply Voltage	V_{CC}	$\pm 5\%$	4.75	5	5.25	V
Current Consumption	I_C	$I_P = 0$	-	3.5	4	mA
Power ON Time	t_{PO}	$V_{CC} \geq 2.5\text{ V}$	-	200	-	μs
Primary Conductor Input Resistance	R_{IN}	$T_A = 25\text{ }^\circ\text{C}$	-	0.1	-	$\text{m}\Omega$
Output Impedance	R_{OUT}	-	-	2	5	Ω
Load Resistance	R_L	$I_P = 0$ to $\pm I_{PN}$	1	10	-	$\text{k}\Omega$
Static Performance Data						
Accuracy	X_G	$T_A = 25\text{ }^\circ\text{C}$, $I_P = 0$ to $\pm I_{PN}$	-	± 1	-	% I_{PN}
		$T_A = -40\text{ }^\circ\text{C}$ to $+105\text{ }^\circ\text{C}$, $I_P = 0$ to $\pm I_{PN}$	-3	± 2	3	
Linearity	ε_L	$I_P = 0$ to $\pm I_{PN}$	-	0.5	1	% I_{PN}
		$I_P = 0$ to $\pm I_{PM}$	-	1	1.5	% I_{PM}
Sensitivity Error	ε_S	$T_A = 25\text{ }^\circ\text{C}$, $I_P = 0$ to $\pm I_{PN}$	-1	-	1	%
		$T_A = -40\text{ }^\circ\text{C}$ to $+105\text{ }^\circ\text{C}$, $I_P = 0$ to $\pm I_{PN}$	-1.5	-	1.5	
Offset Error	V_{OE}	$T_A = 25\text{ }^\circ\text{C}$, $I_P = 0$, $V_{OUT} - V_{REF}$	-5	-	5	mV
		$T_A = -40\text{ }^\circ\text{C}$ ~ $+105\text{ }^\circ\text{C}$, $I_P = 0$, $V_{OUT} - V_{REF}$	-20	± 12	20	
Hysteresis	V_{OH}	$I_P = \pm I_{PM} \rightarrow 0$	-5	-	5	mV
Dynamic Performance Data						
Response Time	t_R	$di/dt > 100\text{ A}/\mu\text{s}$, 90% of V_{OUT} to 90% of I_{PN}	-	0.5	-	μs
Delay Time	t_D	500 kHz sine wave	-	0.3	-	μs
Bandwidth	BW	-3 dB	DC	600	-	kHz
Output Noise	V_N	DC to 10 kHz	-	5	-	mV_{PP}
		DC to 100 kHz	-	15	-	
		DC to 1 MHz	-	20	-	

6. TMR7303-050D/P1 Specifications

$T_A = 25\text{ }^\circ\text{C}$, $V_{CC} = 5\text{ V}$, $R_L = 10\text{ k}\Omega$, unless otherwise noted

Parameter	Symbol	Conditions	Min.	Typ.	Max.	Unit
General Electrical Data						
Primary Nominal Current	I_{PN}	TMR7303-050D/P1	-	50	-	A
Primary Current Measuring Range	I_{PM}	TMR7303-050D/P1	-125	-	125	A
Sensitivity	S	TMR7303-050D/P1	-	16	-	mV/A
Reference Voltage Output	V_{REF}	$T_A = 25\text{ }^\circ\text{C}$	2.49	-	2.51	V
		$T_A = -40\text{ }^\circ\text{C to } +105\text{ }^\circ\text{C}$	2.48	-	2.52	
Output Voltage	V_{OUT}	$I_P = 0\text{ to } \pm I_{PM}$	-	$V_{REF} + 0.8 \times I_P/I_{PN}$	-	V
Supply Voltage	V_{CC}	$\pm 5\%$	4.75	5	5.25	V
Current Consumption	I_C	$I_P = 0$	-	3.5	4	mA
Power ON Time	t_{PO}	$V_{CC} \geq 2.5\text{ V}$	-	200	-	μs
Primary Conductor Input Resistance	R_{IN}	$T_A = 25\text{ }^\circ\text{C}$	-	0.1	-	m Ω
Output Impedance	R_{OUT}	-	-	2	5	Ω
Load Resistance	R_L	$I_P = 0\text{ to } \pm I_{PN}$	1	10	-	k Ω
Static Performance Data						
Accuracy	X_G	$T_A = 25\text{ }^\circ\text{C}$, $I_P = 0\text{ to } \pm I_{PN}$	-	± 1	-	% I_{PN}
		$T_A = -40\text{ }^\circ\text{C to } +105\text{ }^\circ\text{C}$, $I_P = 0\text{ to } \pm I_{PN}$	-3	± 2	3	
Linearity	ε_L	$I_P = 0\text{ to } \pm I_{PN}$	-	0.5	1	% I_{PN}
		$I_P = 0\text{ to } \pm I_{PM}$	-	1	1.5	% I_{PM}
Sensitivity Error	ε_S	$T_A = 25\text{ }^\circ\text{C}$, $I_P = 0\text{ to } \pm I_{PN}$	-1	-	1	%
		$T_A = -40\text{ }^\circ\text{C to } +105\text{ }^\circ\text{C}$, $I_P = 0\text{ to } \pm I_{PN}$	-1.5	-	1.5	
Offset Error	V_{OE}	$T_A = 25\text{ }^\circ\text{C}$, $I_P = 0$, $V_{OUT} - V_{REF}$	-5	-	5	mV
		$T_A = -40\text{ }^\circ\text{C} \sim +105\text{ }^\circ\text{C}$, $I_P = 0$, $V_{OUT} - V_{REF}$	-20	± 12	20	
Hysteresis	V_{OH}	$I_P = \pm I_{PM} \rightarrow 0$	-5	-	5	mV
Dynamic Performance Data						
Response Time	t_R	$di/dt > 100\text{ A}/\mu\text{s}$, 90% of V_{OUT} to 90% of I_{PN}	-	0.5	-	μs
Delay Time	t_D	500 kHz sine wave	-	0.3	-	μs
Bandwidth	BW	-3 dB	DC	600	-	kHz
Output Noise	V_N	DC to 10 kHz	-	5	-	mV _{pp}
		DC to 100 kHz	-	15	-	
		DC to 1 MHz	-	20	-	

7. TMR7303-080D/P1 Specifications

$T_A = 25\text{ }^\circ\text{C}$, $V_{CC} = 5\text{ V}$, $R_L = 10\text{ k}\Omega$, unless otherwise noted

Parameter	Symbol	Conditions	Min.	Typ.	Max.	Unit
General Electrical Data						
Primary Nominal Current	I_{PN}	TMR7303-080D/P1	-	80	-	A
Primary Current Measuring Range	I_{PM}	TMR7303-080D/P1	-200	-	200	A
Sensitivity	S	TMR7303-080D/P1	-	10	-	mV/A
Reference Voltage Output	V_{REF}	$T_A = 25\text{ }^\circ\text{C}$	2.49	-	2.51	V
		$T_A = -40\text{ }^\circ\text{C}$ to $+105\text{ }^\circ\text{C}$	2.48	-	2.52	
Output Voltage	V_{OUT}	$I_P = 0$ to $\pm I_{PM}$	-	$V_{REF} + 0.8 \times I_P / I_{PN}$	-	V
Supply Voltage	V_{CC}	$\pm 5\%$	4.75	5	5.25	V
Current Consumption	I_C	$I_P = 0$	-	3.5	4	mA
Power ON Time	t_{PO}	$V_{CC} \geq 2.5\text{ V}$	-	200	-	μs
Primary Conductor Input Resistance	R_{IN}	$T_A = 25\text{ }^\circ\text{C}$	-	0.1	-	$\text{m}\Omega$
Output Impedance	R_{OUT}	-	-	2	5	Ω
Load Resistance	R_L	$I_P = 0$ to $\pm I_{PN}$	1	10	-	$\text{k}\Omega$
Static Performance Data						
Accuracy	X_G	$T_A = 25\text{ }^\circ\text{C}$, $I_P = 0$ to $\pm I_{PN}$	-	± 1	-	% I_{PN}
		$T_A = -40\text{ }^\circ\text{C}$ to $+105\text{ }^\circ\text{C}$, $I_P = 0$ to $\pm I_{PN}$	-3	± 2	3	
Linearity	ε_L	$I_P = 0$ to $\pm I_{PN}$	-	0.5	1	% I_{PN}
		$I_P = 0$ to $\pm I_{PM}$	-	1	1.5	% I_{PM}
Sensitivity Error	ε_S	$T_A = 25\text{ }^\circ\text{C}$, $I_P = 0$ to $\pm I_{PN}$	-1	-	1	%
		$T_A = -40\text{ }^\circ\text{C}$ to $+105\text{ }^\circ\text{C}$, $I_P = 0$ to $\pm I_{PN}$	-1.5	-	1.5	
Offset Error	V_{OE}	$T_A = 25\text{ }^\circ\text{C}$, $I_P = 0$, $V_{OUT} - V_{REF}$	-5	-	5	mV
		$T_A = -40\text{ }^\circ\text{C}$ ~ $+105\text{ }^\circ\text{C}$, $I_P = 0$, $V_{OUT} - V_{REF}$	-20	± 15	20	
Hysteresis	V_{OH}	$I_P = \pm I_{PM} \rightarrow 0$	-6	-	6	mV
Dynamic Performance Data						
Response Time	t_R	$di/dt > 100\text{ A}/\mu\text{s}$, 90% of V_{OUT} to 90% of I_{PN}	-	0.5	-	μs
Delay Time	t_D	500 kHz sine wave	-	0.3	-	μs
Bandwidth	BW	-3 dB	DC	600	-	kHz
Output Noise	V_N	DC to 10 kHz	-	5	-	mV_{PP}
		DC to 100 kHz	-	15	-	
		DC to 1 MHz	-	20	-	

8. TMR7303-120D/P1 Specifications

$T_A = 25\text{ }^\circ\text{C}$, $V_{CC} = 5\text{ V}$, $R_L = 10\text{ k}\Omega$, unless otherwise noted

Parameter	Symbol	Conditions	Min.	Typ.	Max.	Unit
General Electrical Data						
Primary Nominal Current	I_{PN}	TMR7303-120D/P1	-	120	-	A
Primary Current Measuring Range	I_{PM}	TMR7303-120D/P1	-300	-	300	A
Sensitivity	S	TMR7303-120D/P1	-	6.667	-	mV/A
Reference Voltage Output	V_{REF}	$T_A = 25\text{ }^\circ\text{C}$	2.49	-	2.51	V
		$T_A = -40\text{ }^\circ\text{C to } +105\text{ }^\circ\text{C}$	2.48	-	2.52	
Output Voltage	V_{OUT}	$I_P = 0\text{ to } \pm I_{PM}$	-	$V_{REF} + 0.8 \times I_P / I_{PN}$	-	V
Supply Voltage	V_{CC}	$\pm 5\%$	4.75	5	5.25	V
Current Consumption	I_C	$I_P = 0$	-	3.5	4	mA
Power ON Time	t_{PO}	$V_{CC} \geq 2.5\text{ V}$	-	200	-	μs
Primary Conductor Input Resistance	R_{IN}	$T_A = 25\text{ }^\circ\text{C}$	-	0.1	-	m Ω
Output Impedance	R_{OUT}	-	-	2	5	Ω
Load Resistance	R_L	$I_P = 0\text{ to } \pm I_{PN}$	1	10	-	k Ω
Static Performance Data						
Accuracy	X_G	$T_A = 25\text{ }^\circ\text{C}$, $I_P = 0\text{ to } \pm I_{PN}$	-	± 1	-	% I_{PN}
		$T_A = -40\text{ }^\circ\text{C to } +105\text{ }^\circ\text{C}$, $I_P = 0\text{ to } \pm I_{PN}$	-3	± 2	3	
Linearity	ε_L	$I_P = 0\text{ to } \pm I_{PN}$	-	0.5	1	% I_{PN}
		$I_P = 0\text{ to } \pm I_{PM}$	-	1	1.5	% I_{PM}
Sensitivity Error	ε_S	$T_A = 25\text{ }^\circ\text{C}$, $I_P = 0\text{ to } \pm I_{PN}$	-1	-	1	%
		$T_A = -40\text{ }^\circ\text{C to } +105\text{ }^\circ\text{C}$, $I_P = 0\text{ to } \pm I_{PN}$	-1.5	-	1.5	
Offset Error	V_{OE}	$T_A = 25\text{ }^\circ\text{C}$, $I_P = 0$, $V_{OUT} - V_{REF}$	-5	-	5	mV
		$T_A = -40\text{ }^\circ\text{C} \sim +105\text{ }^\circ\text{C}$, $I_P = 0$, $V_{OUT} - V_{REF}$	-20	± 15	20	
Hysteresis	V_{OH}	$I_P = \pm I_{PM} \rightarrow 0$	-8	-	8	mV
Dynamic Performance Data						
Response Time	t_R	$di/dt > 100\text{ A}/\mu\text{s}$, 90% of V_{OUT} to 90% of I_{PN}	-	0.75	-	μs
Delay Time	t_D	500 kHz sine wave	-	0.5	-	μs
Bandwidth	BW	-3 dB	DC	300	-	kHz
Output Noise	V_N	DC to 10 kHz	-	5	-	mV _{pp}
		DC to 100 kHz	-	15	-	
		DC to 1 MHz	-	20	-	

9. Typical Output Characteristics

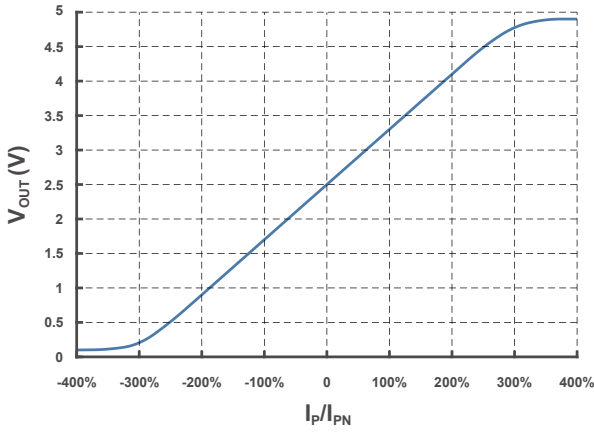

Figure 1. Output voltage vs primary current

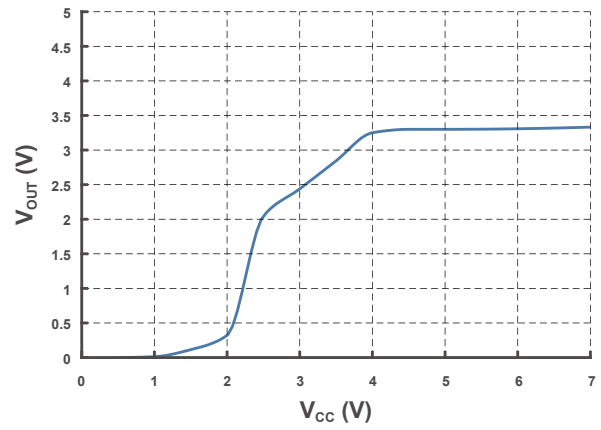

Figure 2. Output voltage vs supply voltage (@ $I_P = I_{PN}$)

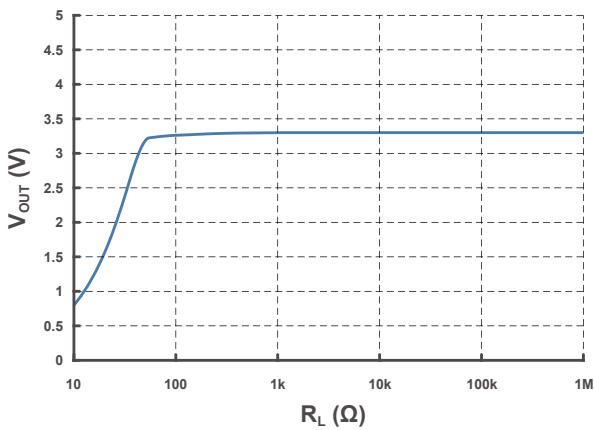

Figure 3. Output voltage vs load resistance (@ $I_P = I_{PN}$)

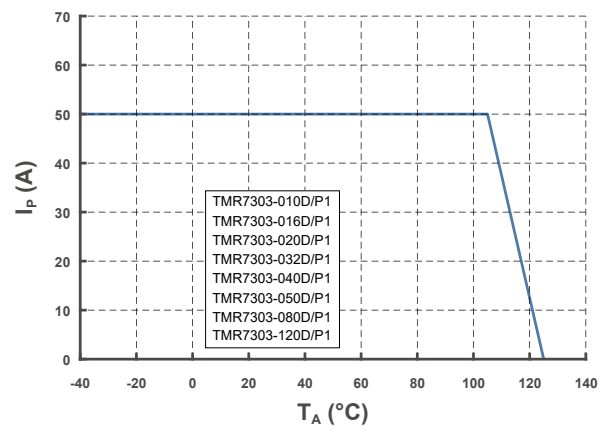

Figure 4. Maximum continuous current (DC)

10. Frequency Response Characteristic

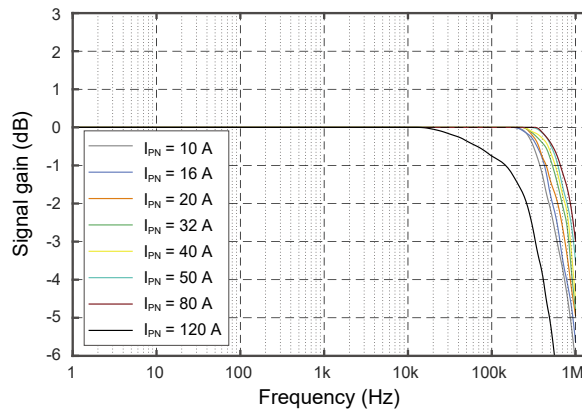

Figure 5. Bode plot

Step Response Time: The Voltage Output signal of current sensor is presented by the yellow CH1 and the pink CH3 is the reference step response input signal. The response time is the time difference between The time interval between primary when the applied step current reaches 90% of its final value, and secondary when the sensor Voltage Output reaches 90% of its output corresponding to the applied current which is approximately 0.4 μ s.

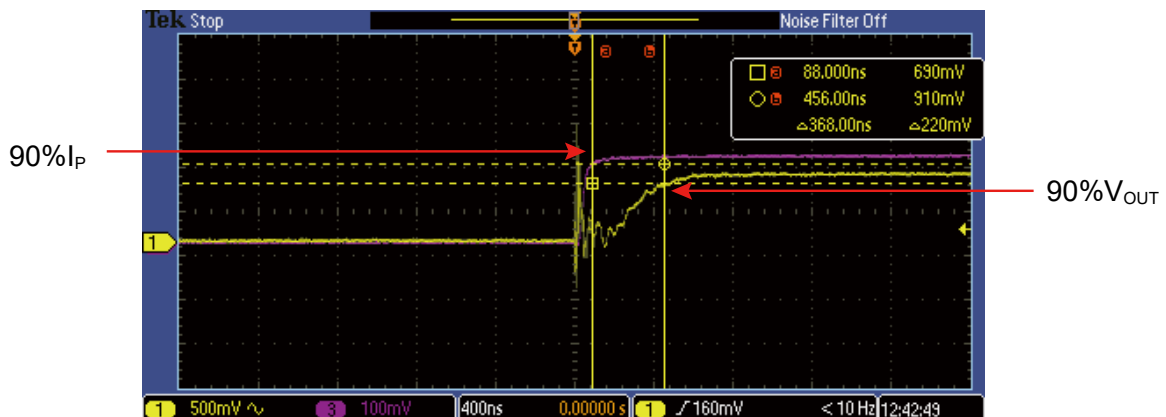

Figure 6. Step signal response time

The Time Delay between primary and the secondary Voltage Output and primary under a pure 500 kHz sine wave injected into the current sensor primary side is approximately 0.3 μ s.

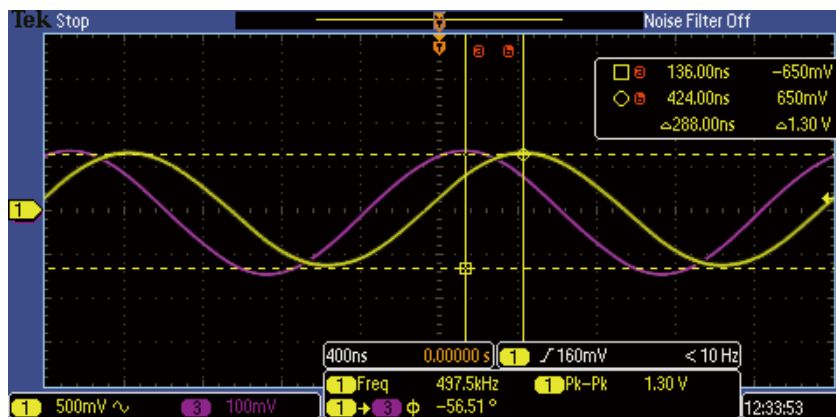

Figure 7. Sine wave signal delay time

11. Parameters Definition and Formula

1) Accuracy

$$X_G = \text{MAX}_{I_p \in [-I_{PN}, I_{PN}]} \left(\frac{V_{OUT} - (I_p \times S + V_{REF})}{I_{PN} \times S} \times 100\% \right)$$

I_p stands for primary current, I_{PN} stands for nominal primary current, V_{OUT} stands for current sensor output voltage at given primary current, S stands for sensitivity, V_{REF} stands for reference voltage output.

2) Sensitivity

$$S = \frac{V_{OUT(@I_{PN})} - V_{OUT(@-I_{PN})}}{2 \times I_{PN}}$$

$V_{OUT(@I_{PN})}$ and $V_{OUT(@-I_{PN})}$ stand for the voltage output at I_{PN} , $-I_{PN}$ respectively.

3) Linearity

$$\epsilon_L = \text{MAX}_{I_p \in [-I_{PN}, I_{PN}]} \left(\frac{|V_{OUT} - (I_p \times \bar{S} + \bar{V}_{REF})|}{I_{PN} \times \bar{S}} \times 100\% \right)$$

\bar{S} , \bar{V}_{REF} stand for the average values of the sensitivity and reference voltage output.

4) Offset Error

$$V_{OE} = V_{OUT(@I_p=0)} - V_{REF}$$

5) Hysteresis

$$V_{OH} = \text{MAX } \Delta H$$

ΔH is the maximum residual voltage between full scale positive and negative nominal current.

12. Dimensions

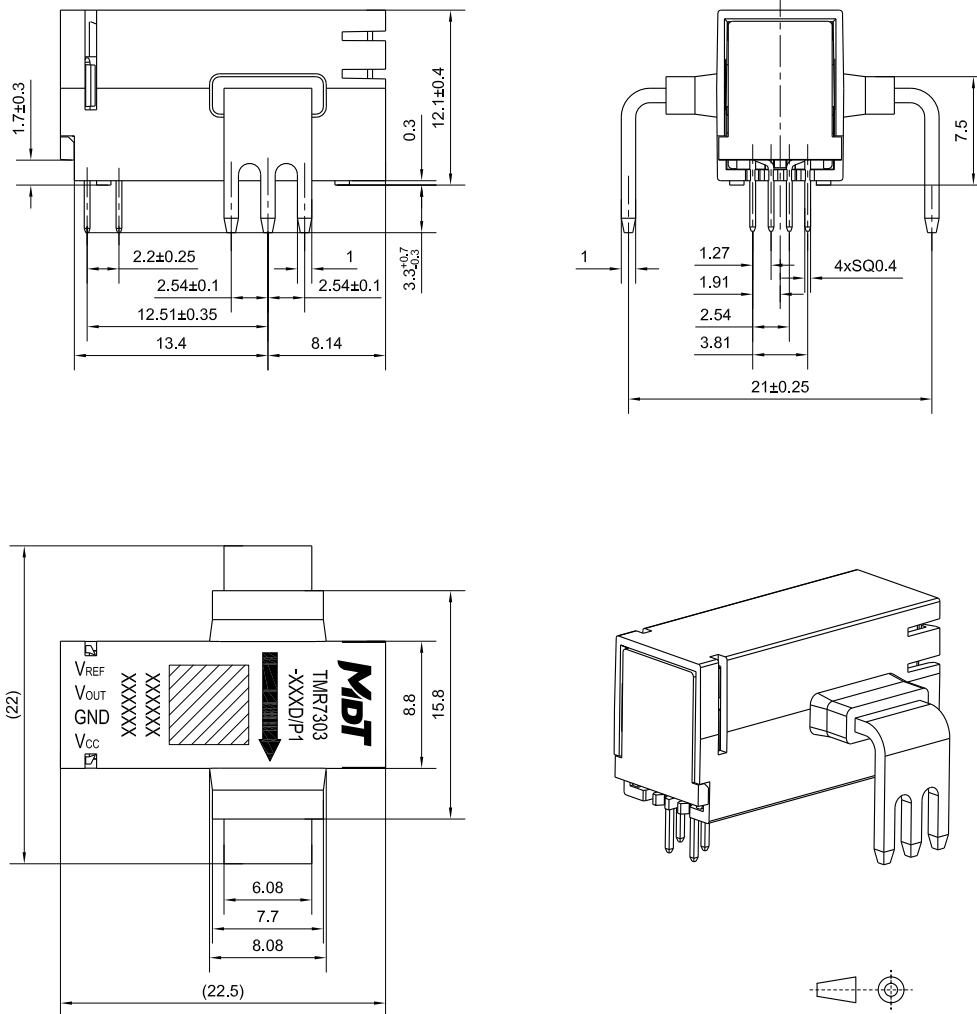
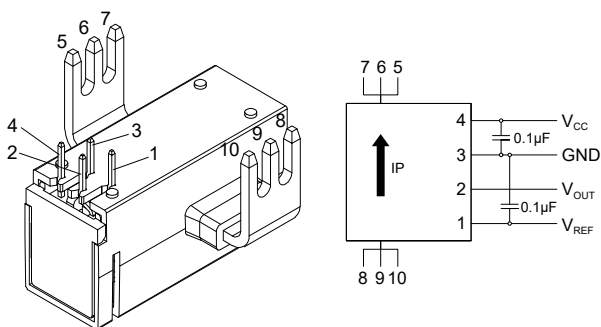

Figure 8. Dimension (unit: mm, tolerances for unmarked scales ± 1 mm)

13. Pin Configuration and Wiring Diagram



Pin Number	Name	Function
1	V_{REF}	Reference voltage output
2	V_{OUT}	Voltage output
3	GND	Ground
4	V_{CC}	Power supply
5 ~ 7	I_{P-}	Primary current (reverse)
8 ~ 10	I_{P+}	Primary current (forward)

Figure 9. Pin configuration and wiring Diagram

14. Recommended PCB Layout

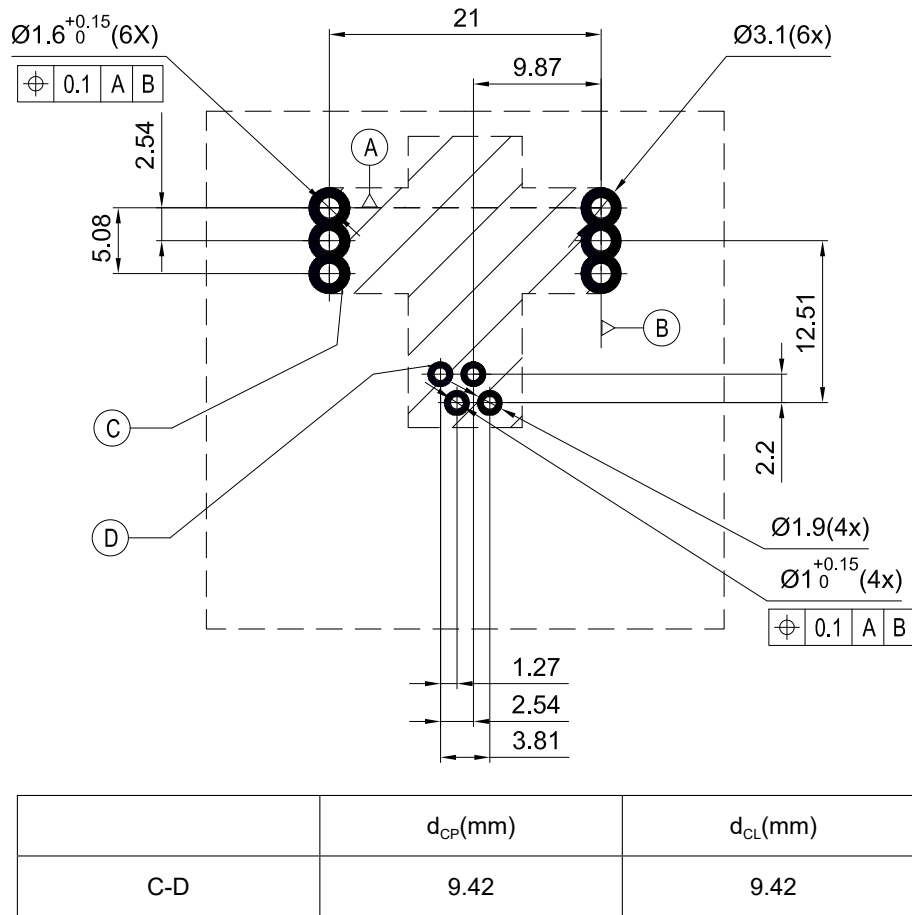

Figure 10. PCB layout

15. Remarks

1. Wave Soldering Profile: Maximum Temperature 260 °C for 10 s.
2. V_{OUT} is positive when the primary current (I_P) is in the same direction as the arrow indication on the label and vice versa.
3. Improper connection may result in permanent damage of the sensor.
4. Bandwidth can be adjusted by adding low pass filter (LPF) between V_{OUT} and GND.
5. The current sensor must be disconnected from the power supply during installation. No other devices are allowed in the projection area under the sensor.
6. Sensor is customizable upon request.
7. Transient surge suppression shall be installed on the line side of this equipment and shall be rated 600 V (phase to ground), 600 V (phase to phase), suitable for overvoltage category III, and shall provide protection for a rated impulse withstand voltage peak of 6 kV or equivalent.

16. Wave Soldering Temperature Curve

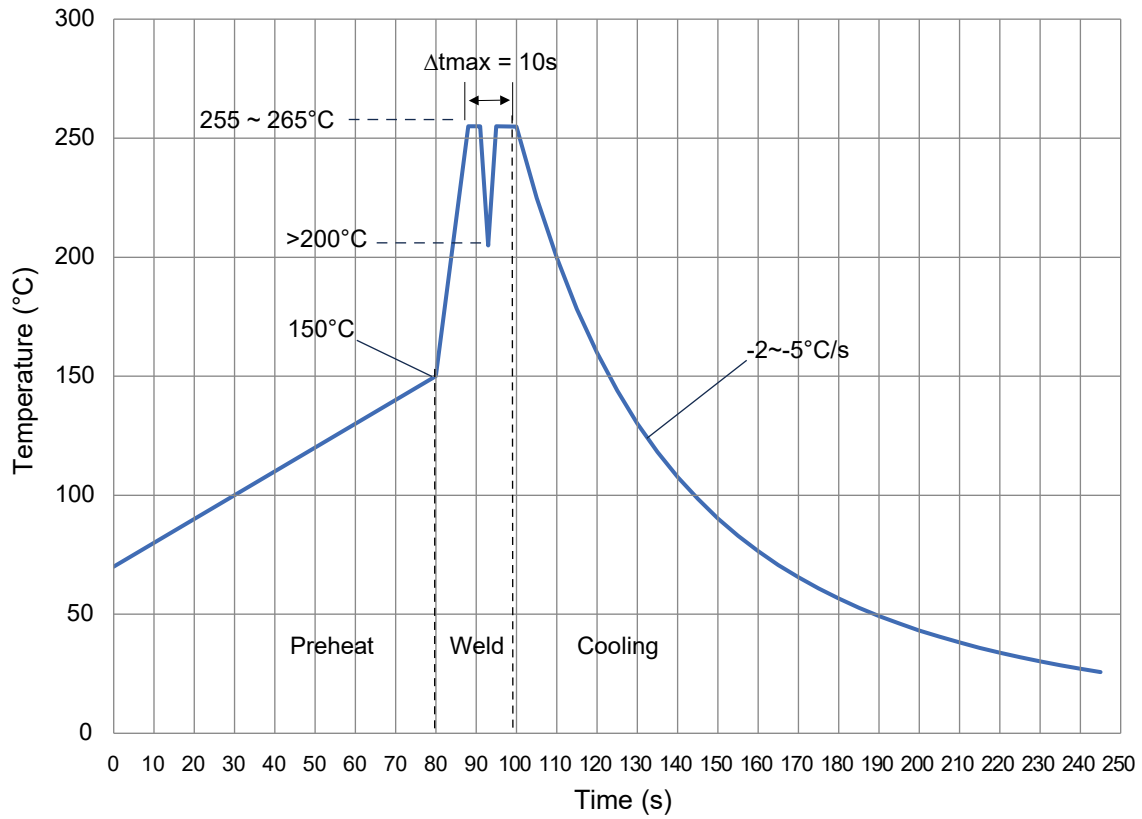

Figure 11. Wave soldering temperature curve

17. Packaging information

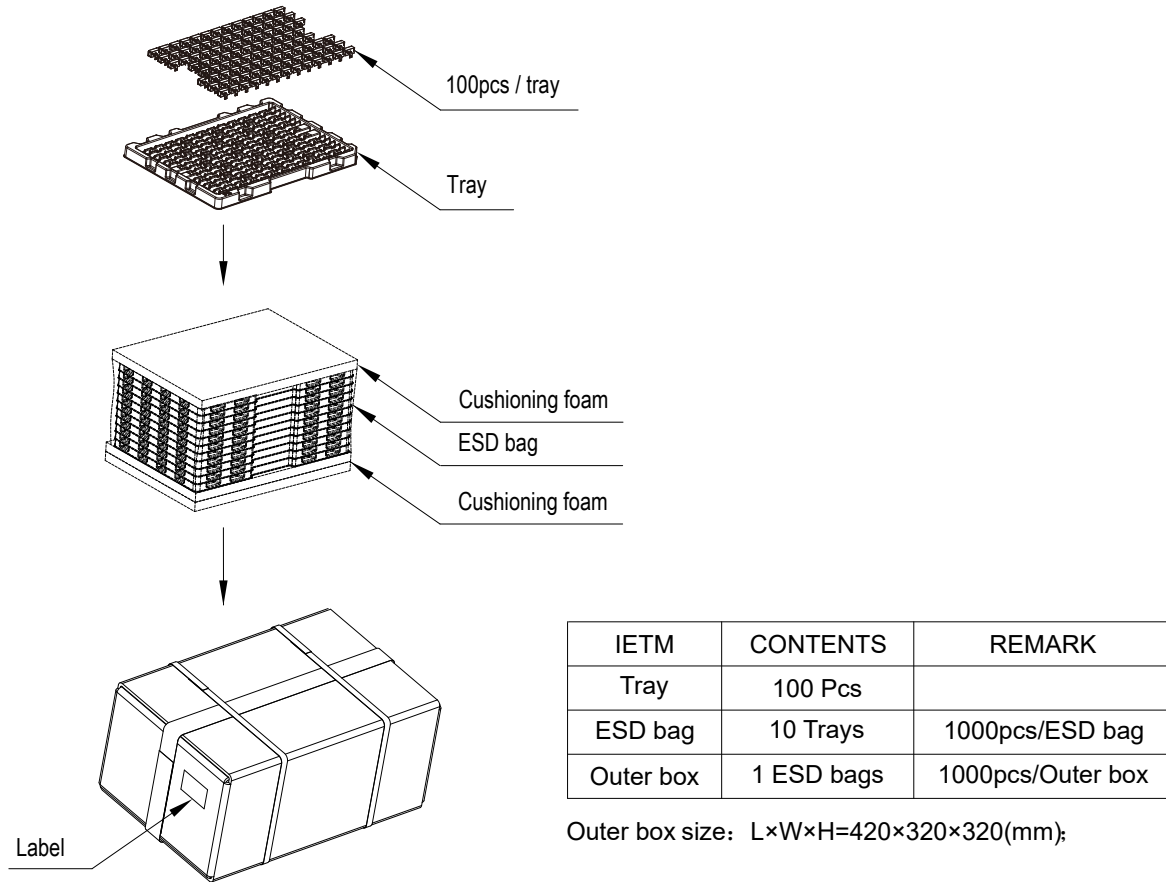

Figure 12. Packaging information

Copyright © 2025 by MultiDimension Technology Co., Ltd.

Information furnished herein by MultiDimension Technology Co., Ltd. (hereinafter MDT) is believed to be accurate and reliable. However, MDT disclaims any and all warranties and liabilities of any kind, with respect to any examples, hints or any performance or use of technical data as described herein and/or any information regarding the application of the product, including without limitation warranties of non-infringement of intellectual property rights of any third party. This document neither conveys nor implies any license under patent or other industrial or intellectual property rights. Customer or any third-party must further determine the suitability of the MDT products for its applications to avoid the applications default of customer or third-party. MDT accept no liability in this respect.

MDT does not assume any liabilities of any indirect, incidental, punitive, special or consequential damages (including without limitation of lost profits, lost savings, business interruption, costs related to the removal or replacement of any products or rework charges) whether or not such damages are based on tort (including negligence), warranty, breach of contract or any other legal theory. Notwithstanding any damages that customer might incur for any reason whatsoever, MDT's aggregate and cumulative liability towards customer for the products described herein shall be limited in accordance with the terms and conditions of commercial sale of MDT.

Absolute maximum ratings are the extreme limits the device will withstand without damage to the MDT product. However, the electrical and mechanical characteristics are not guaranteed as the maximum limits (above recommended operating conditions) are approached. MDT disclaims any and all warranties and liabilities of the MDT product will operate at absolute maximum ratings.

Specifications may change without notice.

Please download latest document from our official website www.dowaytech.com/en.

Recycling

The product(s) in this document need to be handed over to a qualified solid waste management services company for recycling in accordance with relevant regulations on waste classification after the end of the product(s) life.



No.2 Guangdong Road, Zhangjiagang Free Trade Zone, Jiangsu, China

Web: www.dowaytech.com/en E-mail: info@dowaytech.com

