

# TMR8501

## High-precision, Low-noise Linear Magnetic Sensor

### Description

The TMR8501 is a compact and high-precision linear magnetic sensor, featuring low noise and fast response. This sensor is encased in a module-level package measuring 29mm × 18.5mm × 8.6mm. It boasts a measurement range of ±500 μT and supports either single or dual power supply options, with voltage ranges from ±3.3V to ±15V. Operating temperatures range from -40°C to 85°C. Utilizing advanced tunneling magnetoresistance (TMR) technology, the TMR8501 integrates a magnetic field feedback coil and a weak signal conditioning circuit. This configuration allows it to achieve a low noise level of 15 pT/√Hz at 1Hz, linearity of 0.05%, sensitivity temperature drift of 40 PPM, and sensitivity variation of 0.3% across a temperature range of -40°C to 75°C. With a bandwidth of 500 kHz, it enables high-resolution, real-time measurement of weak magnetic fields. The TMR8501 is ideally suited for applications such as environmental magnetic field monitoring, food safety testing, geophysical magnetic detection, traffic monitoring, and magnetic metal detection.

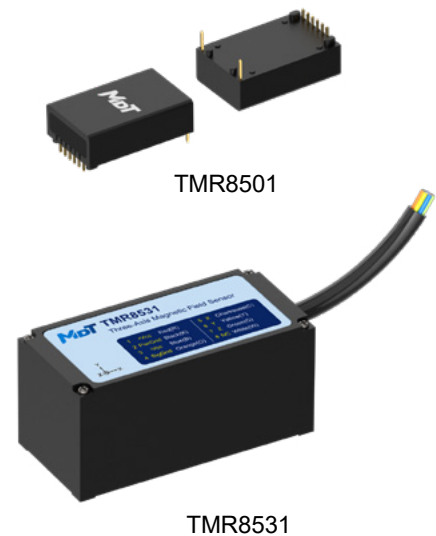

### Features and Benefits

- Low-noise tunnel magnetoresistance technology
- Precision magnetic field feedback technology
- 15 pT/√Hz@1Hz low noise
- 40 PPM sensitivity temperature drift
- 0.05% linear response characteristics
- 500 kHz wide frequency response

### Applications

- Environmental magnetic field monitoring
- Food safety testing
- Geophysical Magnetic Exploration
- Underground pipeline inspection
- Metal anomaly detection
- Traffic vehicle detection

### Selection Guide

Part Number	Sensing Direction	Frequency Response (-3dB)	Magnetic Field Spectral Noise Density	Supply Voltage	Dimension
TMR8501	Single axis	DC to 500 kHz	10 to 20 pT/√Hz@1Hz	5 V to 30 V ±3.3 V to ±15 V	29mm × 18.5mm × 8.6mm
TMR8531	Triaxial	DC to 500 kHz	10 to 20 pT/√Hz@1Hz	±3.3 V to ±15 V	70 mm × 33 mm × 33 mm

## Catalogue

1. Features .....	03
1.1 Functional Block Diagram .....	03
1.2 TMR8501 Pin Definition .....	03
2. Specifications .....	04
3. TMR8501 Mechanical and Interface Parameters .....	04
4. Characteristic Curves .....	05
5. Application Guide.....	06
6. TMR8501 Dimensions .....	07
7. TMR8531 Pin Configuration .....	08
8. TMR8531 Mechanical and Interface Parameters .....	08
9. TMR8531 Dimensions .....	08

## 1. Features

### 1.1 Functional Block Diagram

The TMR8501 magnetoresistive sensor is primarily designed for detecting weak magnetic fields. The block diagram below explores its operating principle. The sensor IC measures the external magnetic field ( $H_{ext}$ ) and outputs a voltage signal. This signal is amplified and passed through a feedback coil, which generates a feedback magnetic field ( $H_{fed}$ ) to counteract  $H_{ext}$ . The feedback loop current ( $I_{fed}$ ) is then measured via the sampling resistor ( $R_s$ ), enabling the detection of the external magnetic field signal. When the feedback stabilizes, the loop operates in a state of deep negative feedback where the feedback magnetic field entirely cancels out  $H_{ext}$ . Consequently, the sensor's output voltage ( $V_{OUT}$ ) varies linearly with changes in  $H_{ext}$ :

$$V_{OUT} = Sen \times H_{ext} + V_{offset}$$

Here,  $Sen$  represents the sensor's sensitivity, and  $V_{offset}$  is the zero offset voltage, which can be adjusted through the sensor's voltage-to-magnetic field relationship ( $V_H$ ). The transfer characteristic curve is derived from empirical testing.

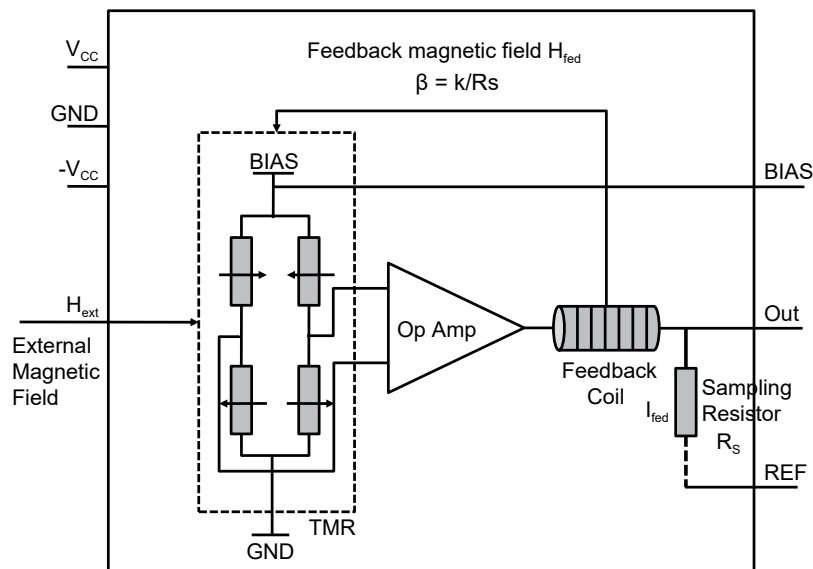

Figure 1. TMR8501 functional block diagram

### 1.2 TMR8501 Pin Definition

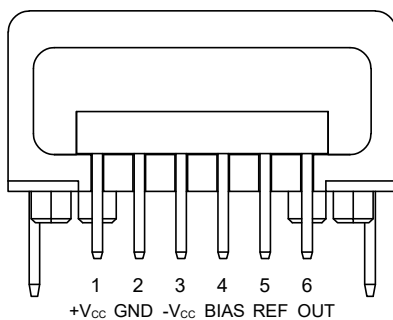

Figure 2. Pin definition

Pin	Name	Function	Reference Connection	
			Single Supply Connection	Dual Supply Connection
1	+V <sub>CC</sub>	Positive supply	Positive supply	Positive supply
2	GND	Ground	Ground	Ground
3	-V <sub>CC</sub>	Negative supply	Ground	Negative supply
4	BIAS	Internal bias voltage	REF	NC
5	REF	Output reference	Bias or external	Ground or external
6	OUT	Output	Output	Output

## 2. Specifications

$V_{CC} = \pm 5\text{ V}$ ,  $T_A = 25\text{ }^\circ\text{C}$

Specification	Symbol	Condition	Min.	Typ.	Max.	Unit
Measuring range	FS	$V_{CC} = \pm 15\text{ V}$	-	$\pm 200$	$\pm 500$	$\mu\text{T}$
Sensitivity	Sen	-200 $\mu\text{T}$ to 200 $\mu\text{T}$	19.50	20.00	20.50	$\text{mV}/\mu\text{T}$
Sensitivity temperature coefficient	TCS	-40 $^\circ\text{C}$ to 75 $^\circ\text{C}$	-	40	-	$\text{PPM}/^\circ\text{C}$
Vertical field sensitivity	YSen	$H_y = -200\text{ } \mu\text{T}$ to $200\text{ } \mu\text{T}$	-	0.04	-	$\text{mV}/\mu\text{T}$
Vertical field sensitivity cross coefficient <sup>1</sup>	YCS	$H_y = -200\text{ } \mu\text{T}$ to $200\text{ } \mu\text{T}$	-	0.25	-	$\%/ \text{Sen}$
Zero magnetic field offset <sup>2</sup>	$H_{\text{offset}}$	$H = 0$	-	-	5	$\mu\text{T}$
Zero offset temperature coefficient <sup>2</sup>	TCH	-40 $^\circ\text{C}$ to 75 $^\circ\text{C}$ , $H = 0$	-	20	-	$\text{nT}/^\circ\text{C}$
Nonlinearity	$\delta_L$	$\pm 200\text{ } \mu\text{T}$	-	0.05	0.1	%
Hysteresis	Hys	$\pm 200\text{ } \mu\text{T}$	-	0.5	1	$\mu\text{T}$
Voltage noise density	$V_N$	$H = 0$ , at 1Hz	-	400	600	$\text{nV}/\sqrt{\text{Hz}}@1\text{Hz}$
Magnetic field noise density	$B_N$	$H = 0$ , at 1Hz	10	15	20	$\text{pT}/\sqrt{\text{Hz}}@1\text{Hz}$
Thermal magnetic field noise density	$B_{\text{NW}}$	$H = 0$ , $f = 1\text{ kHz}$	-	1.0	-	$\text{pT}/\sqrt{\text{Hz}}$
Magnetic field noise peak-to-peak	$B_{\text{NPP}}$	0.1 Hz to 10 Hz	-	0.3	0.4	$\text{nT}_{\text{pp}}$
Output voltage range	$V_{\text{OUT}}$	-	$-V_{CC} + 0.5$	-	$V_{CC} - 0.5$	V
Maximum output current	$I_{\text{OUT}}$	-	-	-	30	mA
Frequency characteristics	FR	-3 dB	-	500	-	kHz
Single supply voltage	$V_{CC}$	-	5	12	30	V
Dual power supply voltage		-	$\pm 3.3$	$\pm 5$	$\pm 15$	V
Static power	$P_W$	$H = 0$ , $\pm 5\text{ V}$	-	10	-	mW
+ $V_{CC}$ static operating current	$I_{Q+}$	$H = 0$	-	3	-	mA
- $V_{CC}$ static operating current	$I_{Q-}$	$H = 0$	-	3	-	mA
Operating temperature	$T_A$	-	-40	-	85	$^\circ\text{C}$
storage temperature	$T_S$	-	-40	-	85	$^\circ\text{C}$

Note:

1. Refers to the output change of an external magnetic field in the direction perpendicular to the sensitivity of the chip surface, and the cross-influence coefficient of the output in the relative sensitivity direction.
2. Users can compensate for zero offset and zero temperature drift as needed.

## 3. TMR8501 Mechanical and Interface Parameters

Name	Parameter	Unit
Dimensions (length × width × height)	29 × 18.5 × 8.6	mm
Weight	8.5	g
Electrical Interface	6 × $\Phi 0.8$ , hole center distance 2.0	mm
Install the positioning interface	2 × $\Phi 2.4$ , hole center distance 14.4 2 × $\Phi 1.3$ , hole center distance 10.0	mm
Sensitive axis direction	Sensor long axis direction	-

## 4. Characteristic Curves

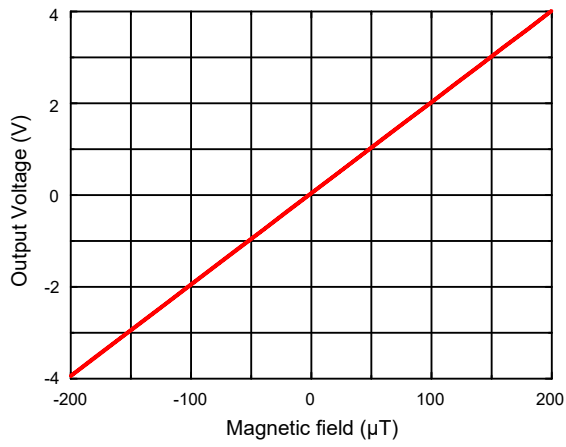

Figure.3 Typical VH transfer curve

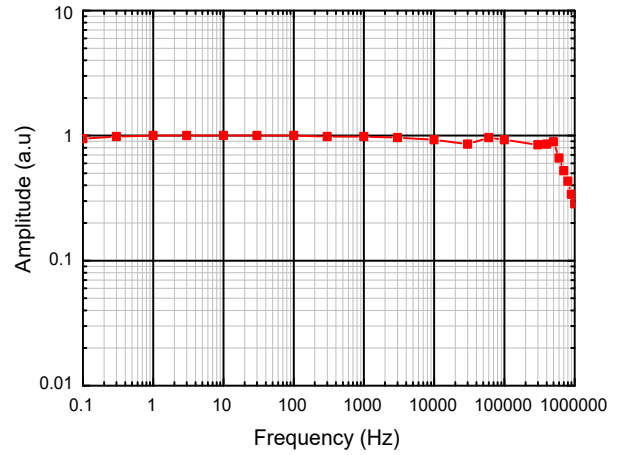

Figure 4. Typical frequency response characteristics

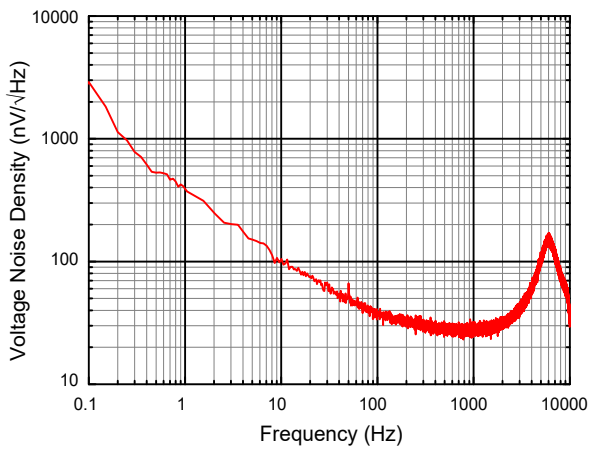

Figure.5 Typical voltage noise spectral density

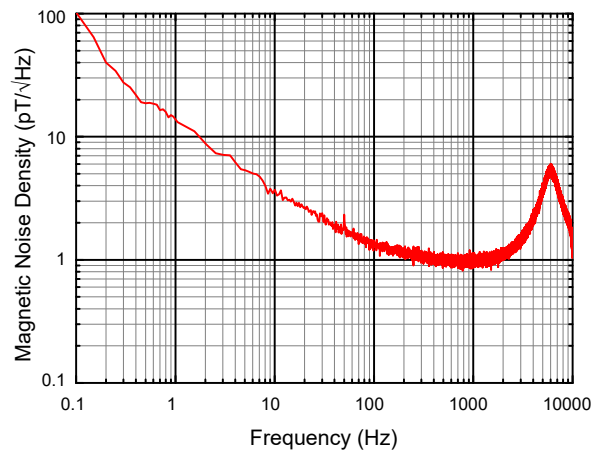

Figure 6. Typical magnetic field noise spectral density curve

## 5. Application Guide

TMR8501 can be operated with either a single or dual power supply setup, featuring an integrated power bypass capacitor that eliminates the need for additional power supply processing. This design effectively suppresses power ripple interference, ensuring stable and reliable operation. To mitigate installation errors, the package includes a specially designed mounting positioning hole. In practice, the sensor simply requires external positive and negative power supplies to function. It incorporates an internal precision magnetic field feedback coil and a signal conditioning circuit for stable performance and ease of use.

To enhance zero-point accuracy, users can utilize the reference point REF (Pin 5). By connecting an externally constructed reference voltage, this setup compensates for zero offset and temperature drift. Depending on the application, the compensation reference point can be adjusted using resistor voltage division, external network voltage division, or microcontroller-controlled DAC to modify the analog output voltage of the reference point. In specific scenarios, the output of the first sensor ( $V_{OUT}$ ) can be linked to the output reference point of the second sensor REF (Pin 5), facilitating differential output between the two sensors. This connection helps better counteract the common-mode magnetic interference from external environments. For more details, please refer to the typical application reference circuit provided.

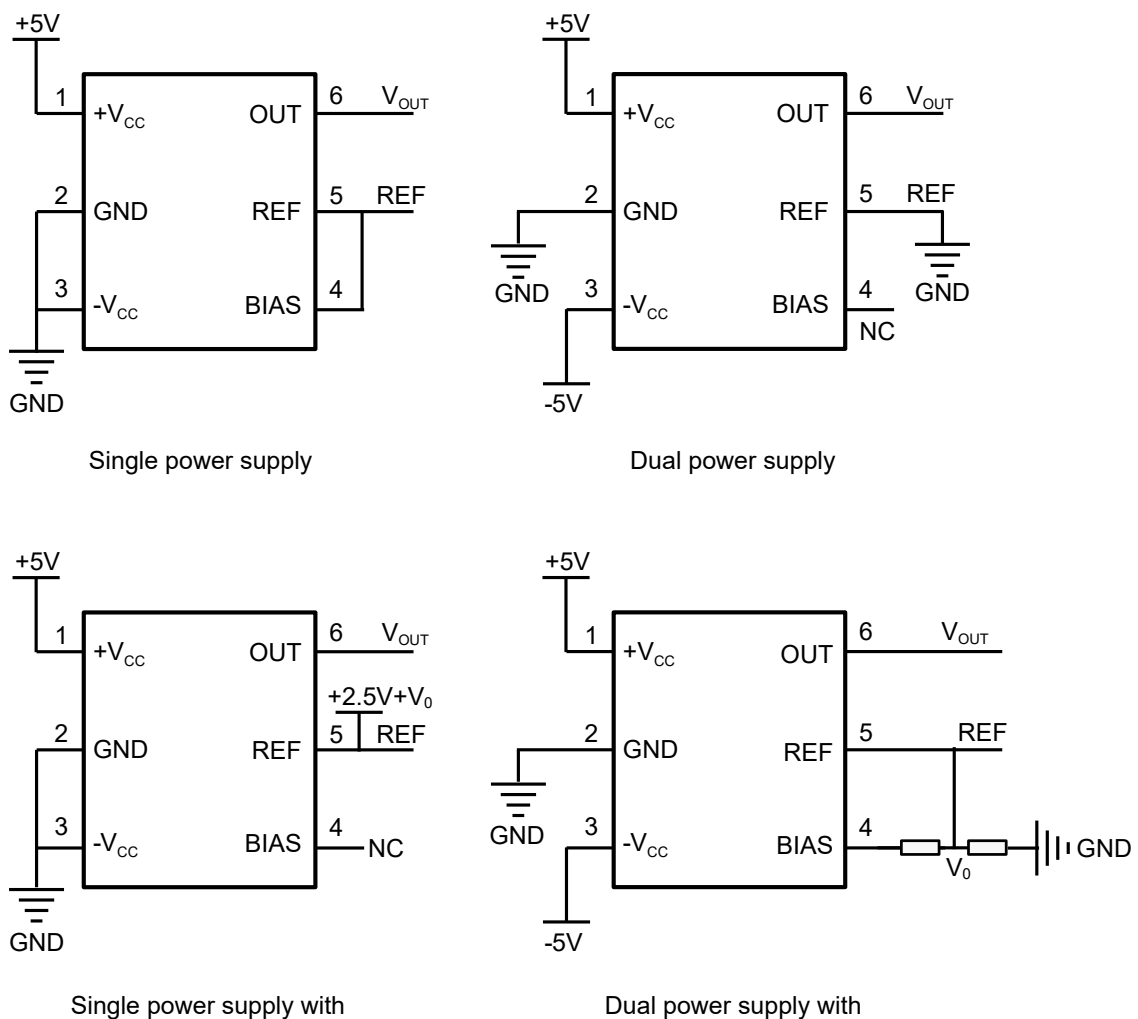

Figure 7. Typical application reference circuit

## 6. TMR8501 Dimensions

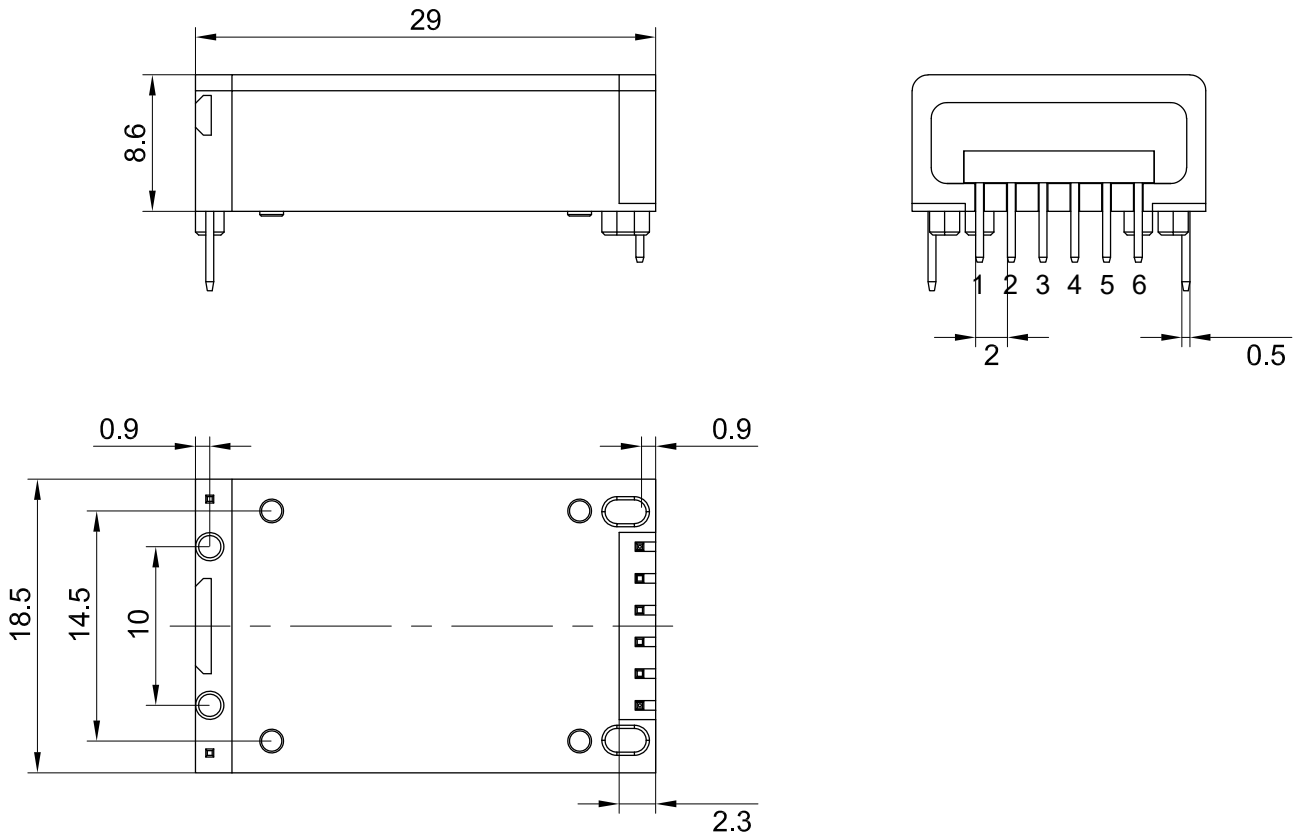

Figure 8. Dimensions (unit: mm )

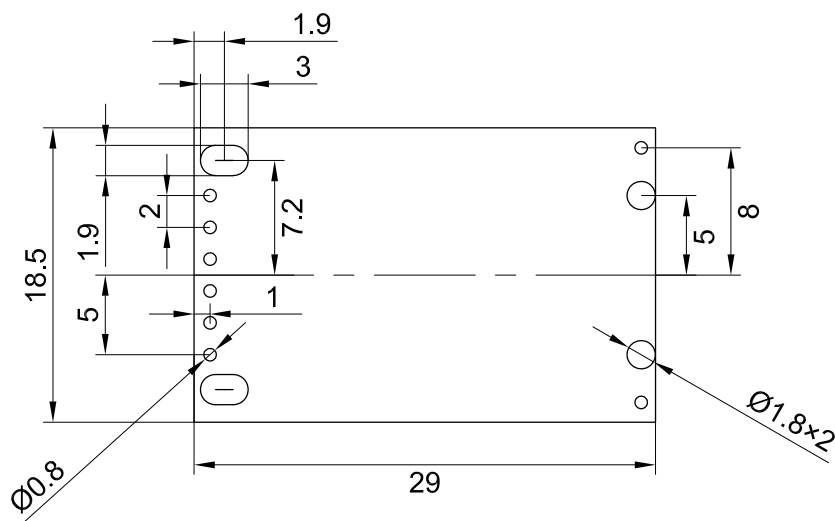

Figure 9. PCB board opening dimensions (unit: mm )

# TMR8531

High-precision, Low-noise, Three Triaxial Linear Magnetic Sensor

## 7. TMR8531 Pin Configuration

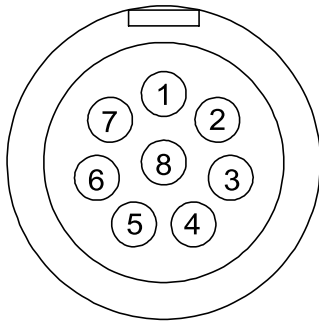

Figure 10. Pin definition

Pin	Name	Colour	Function
1	+V <sub>CC</sub>	Red (R)	Positive Supply Voltage
2	PWR GND	Black (K)	Power Ground
3	-V <sub>CC</sub>	Blue (B)	Negative Supply Voltage
4	SIG GND	Orange (O)	Signal Ground
5	X	Chartreuse (C)	X Axis Output
6	Y	Yellow (Y)	Y Axis Output
7	Z	Green (G)	Z Axis Output
8	NC	White (W)	Not Connected

## 8. TMR8531 Mechanical and Interface Parameters

Name	Parameter	Unit
Dimensions (length × width × height)	70 × 33 × 33	mm
Weight	80 (Cable not included)	g
Electrical Interface	FGG 1B 8 Pin Connector	-
Cable Length	1	m
Sensing Direction	X/Y/Z Axes	-
X/Y/Z Axis Deviation	< 0.5	deg

## 9. TMR8531 Dimensions

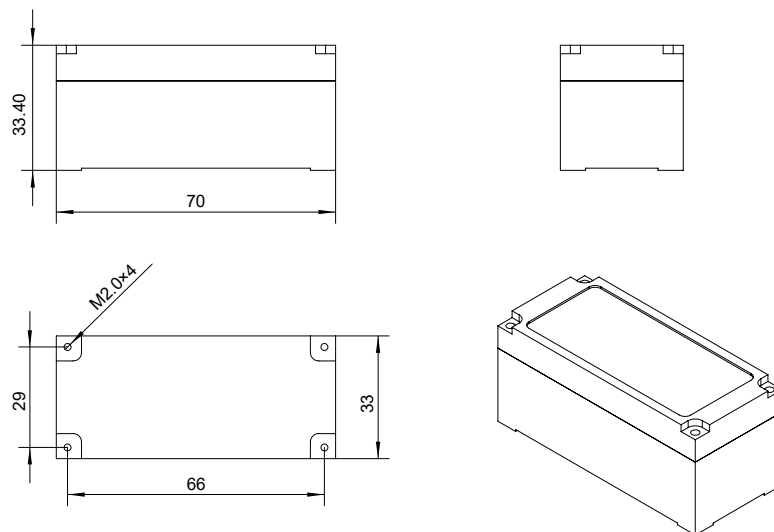

Figure 11. Dimensions (unit: mm )

Copyright © 2025 by MultiDimension Technology Co., Ltd.

Information furnished herein by MultiDimension Technology Co., Ltd. (hereinafter MDT) is believed to be accurate and reliable. However, MDT disclaims any and all warranties and liabilities of any kind, with respect to any examples, hints or any performance or use of technical data as described herein and/or any information regarding the application of the product, including without limitation warranties of non-infringement of intellectual property rights of any third party. This document neither conveys nor implies any license under patent or other industrial or intellectual property rights. Customer or any third-party must further determine the suitability of the MDT products for its applications to avoid the applications default of customer or third-party. MDT accept no liability in this respect.

MDT does not assume any liabilities of any indirect, incidental, punitive, special or consequential damages (including without limitation of lost profits, lost savings, business interruption, costs related to the removal or replacement of any products or rework charges) whether or not such damages are based on tort (including negligence), warranty, breach of contract or any other legal theory. Notwithstanding any damages that customer might incur for any reason whatsoever, MDT's aggregate and cumulative liability towards customer for the products described herein shall be limited in accordance with the terms and conditions of commercial sale of MDT.

Absolute maximum ratings are the extreme limits the device will withstand without damage to the MDT product. However, the electrical and mechanical characteristics are not guaranteed as the maximum limits (above recommended operating conditions) are approached. MDT disclaims any and all warranties and liabilities of the MDT product will operate at absolute maximum ratings.

Specifications may change without notice.

Please download latest document from our official website [www.dowaytech.com/en](http://www.dowaytech.com/en).

## Recycling

The product(s) in this document need to be handed over to a qualified solid waste management services company for recycling in accordance with relevant regulations on waste classification after the end of the product(s) life.



No.2 Guangdong Road, Zhangjiagang Free Trade Zone, Jiangsu, China

Web: [www.dowaytech.com/en](http://www.dowaytech.com/en) E-mail: [info@dowaytech.com](mailto:info@dowaytech.com)

