

HFM2905

Single-Axis Analog High-Frequency Magnetometer

Description

The HFM2905 is a single-axis, analog, high-frequency magnetometer that measures magnetic-field signals aligned with the probe axis. It covers DC to 1.6 MHz magnetic-field bandwidth and supports AC field amplitudes from 0.1 Gs to 2 Gs.

To simplify bench characterization, HFM2905 combines the magnetic sensor, on-board signal conditioning, USB +5V power input, and a BNC analog voltage output. The BNC interface is intended for direct connection to an oscilloscope or DAQ, enabling immediate visualization of the output waveform and straightforward extraction of magnetic-field amplitude and frequency.



HFM2905 Magnetometer



HFM2905 Calibration Kit

Features and Benefits

- Tunneling magnetoresistance (TMR) technology
- Magnetic-field amplitude: 0.1 Gs to 2 Gs
- Frequency response: DC to 1.6 MHz
- USB bus powered
- BNC signal output interface
- Manually adjustable signal bandwidth ranges (~1 kHz, ~100 kHz, ~1.6 MHz)
- Manually adjustable output gain factors (1×, 2×, 5×, 10×, 20×)
- Manually selectable DC/AC output mode
- Manually adjustable TMR sensor output voltage V_{OFFSET}
- Manually adjustable DC output signal V_{OFFSET} level
- RoHS and REACH compliant

Applications

- Laboratory measurement of AC magnetic-field signals
- Automated data acquisition and control
- Materials research
- Non-destructive testing
- Education
- Hobbyist / DIY projects
- Oscilloscope probe

Selection Guide

Part Number	Magnetic Field Range (Gs)	Measurement Frequency (MHz)	Operating Temperature (°C)	Supply Voltage (V)	Analog Output	Low-Pass Cutoff Bands	Gain	Accessories
HFM2905	0.1 ~ 2	DC ~ 1.6	-40 ~ 125	5.0	BNC	~1kHz, ~100kHz, ~1.6MHz	1x, 2x, 5x, 10x, 20x	Calibration kit; USB to Type-C adapter

Table of Contents

1. Functional Block Diagram.....	03
2. Hardware Description	04
3. Absolute Maximum Ratings	05
4. Electrical Specifications.....	05
5. DC Output Voltage vs. Magnetic Field Hysteresis Loop.....	06
6. Amplitude-Frequency Response	06
7. Magnetometer Zero Adjustment	07
8. Magnetometer Calibration	08
9. Applications	10
10. Dimensions.....	11

1. Functional Block Diagram

As shown in Figure 1, the HFM2905 magnetometer is powered through the USB interface (USB +5.0 V and GND). Connected to Power Circuit 1, which provides two functions:

1. Indicator LED function, consisting of a current-limiting resistor in series with an LED;
2. A dual-output LDO that generates positive and negative supply voltages V+ and V-, providing power for the magnetic sensor IC and its signal-processing circuitry.

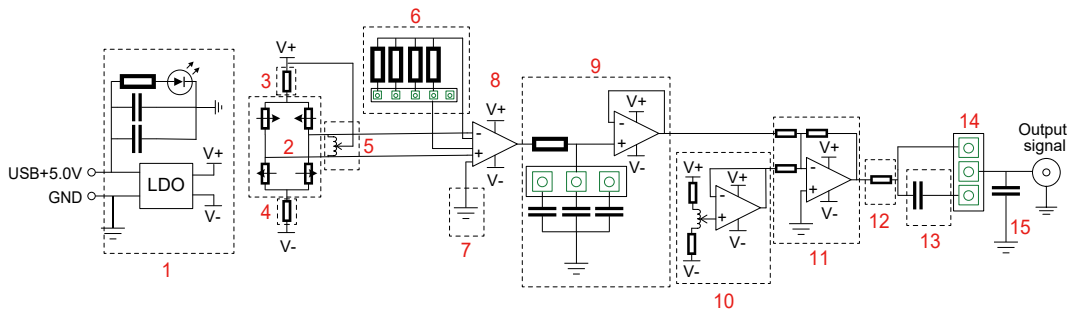

Figure 1. HFM2905 Magnetometer Schematic

In Figure 1: block 2 is the magnetic sensor IC TMR2905, used to measure AC/DC magnetic-field signals. Blocks 3 and 4 are voltage-divider resistors that are used to set the operating voltage of magnetic sensor 2. The sensor operating voltage is:

$$\text{Equation 1: } V = \frac{R_{2905}}{R_{2905} + 2 \times R_S} \times V_S$$

Where R_{2905} is the resistance of sensor 2, R_S is the divider resistor, and $V_S = V_+ - V_-$ is the supply voltage. The V_{OFFSET} zeroing circuit of TMR2905 is implemented by potentiometer 5. The wiper (center tap) of potentiometer 5 is directly connected to V_+ , and the two ends are connected to the two signal output terminals of the TMR2905 full bridge. By adjusting potentiometer 5, the TMR2905 output voltage is set to 0 at zero magnetic field.

Assume the intrinsic relationship between the TMR2905 output voltage V and external magnetic field H is:

$$\text{Equation 2: } V = S \times H + V_{\text{OFFSET0}}$$

Where S is the intrinsic sensitivity of TMR2905 and V_{OFFSET0} is the intrinsic offset voltage. The V_{OFFSET1} zeroing circuit 5 compensates V_{OFFSET0} , so that the instrumentation amplifier output becomes:

$$\text{Equation 3: } V = S \times H + (V_{\text{OFFSET0}} + V_{\text{OFFSET1}}) = S \times H$$

$$V_{\text{OFFSET1}} = -V_{\text{OFFSET0}}$$

The two output signals from sensor 2 are fed into the two differential inputs of instrumentation amplifier 8. Block 6 is the gain-selection circuit, consisting of four resistors plus one “open” position, providing selectable gains of 1×, 2×, 5×, 10×, and 20×. Block 7 is the reference voltage V_{REF} of instrumentation amplifier 8, directly tied to ground. Block 9 is a low-pass filter circuit, consisting of resistor R and capacitor C . There are three capacitors selectable by a slide switch to set cutoff frequencies of ~1kHz, ~100kHz, and ~1.6MHz. An op-amp voltage follower buffers the filtered output.

In Figure 1: Block 11 is an op-amp summing amplifier. 10 is a voltage adjuster consisting of a potentiometer, two limiting resistors, and an op-amp follower. The V_{OFFSET2} generated by 10 and the filtered signal from 9 are summed in 11, enabling output zeroing. When the external magnetic field is $H_{\text{EX}} = H_{\text{DC}} + h_{\text{AC}}$, the output is:

$$\text{Equation 4: } V = G \times S \times (H_{\text{DC}} + h_{\text{AC}})$$

After applying V_{OFFSET2}

$$\text{Equation 5: } V = G \times S \times h_{\text{AC}} + (G \times H_{\text{DC}} + V_{\text{OFFSET2}}) = G \times S \times h_{\text{AC}}$$

$$V_{\text{OFFSET2}} = -G \times H_{\text{DC}}$$

That is, V_{OFFSET2} is used to compensate the DC component $G \times H_{\text{DC}}$.

In Figure 1: Block 12 is resistor R_{SUB} , used to suppress oscillation in the summing amplifier. Block 13 is capacitor C , used to remove the DC component from the output signal to obtain the AC signal. Block 14 is the DC/AC output selection switch: the upper position outputs the DC signal (DC + AC components), and the lower position outputs the AC signal (AC component only). Block 15 is a high-frequency bypass/filter capacitor. The final magnetometer signal is output through the BNC connector.

2. Hardware Description

Figure 2 shows the HFM2905 magnetic probe. The sensing axis 1 is along the axial direction. The sensor IC 2 at the probe tip is TMR2905.

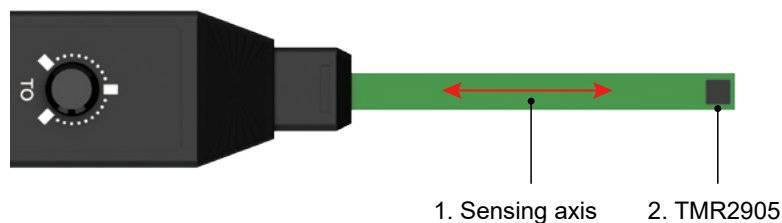

Figure 2. HFM2905 Magnetometer

Figure 3 shows the HFM2905 hardware and controls:

1. Magnetic probe
2. TMR offset Knob (TO)
3. Gain selection slide switch (Gain)
4. Input measurement bandwidth selection slide switch (FS)
5. Output signal zeroing knob (SO)
6. DC/AC output mode selection switch
7. Power indicator LED
8. Power/signal cable

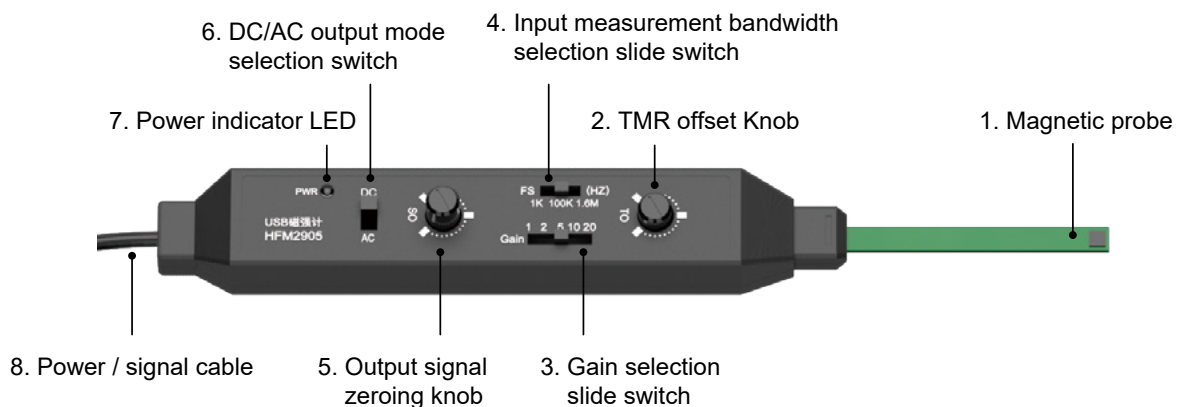

Figure 3. HFM2905 Magnetometer Panel

3. Absolute Maximum Ratings

Parameters	Symbol	Min.	Max.	Unit
External magnetic-field frequency	F	0	1.6	MHz
External magnetic field	H _{EXT}	0.1	2	Gs
Operating ambient temperature	T _A	-40	125	°C
Storage ambient temperature	T _{STG}	-50	150	°C

4. Electrical Specifications

Parameter	Condition	Min.	Typ.	Max.	Unit
Operating voltage	From USB	-	5	-	V
Sensing axis	Parallel to axial direction	-	-	-	-
Cable length	-	-	1	-	m
Power interface	USB 2.0 / Type-C adapter	-	-	-	-
Signal interface	BNC	-	-	-	-
Saturation magnetic field strength	H _{SAT}	-10	-	+10	Gs
Linear magnetic field range	-	-2	-	+2	Gs
Minimum magnetic field	H _{MIN}	-	0.001	-	Gs
Nonlinearity	Within ±2 Gs	-	2	-	%FS
Temperature coefficient of resistance	H = 0 Gs	-	-500	-	PPM/°C

5. DC Output Voltage vs. Magnetic Field Hysteresis Loop

Figure 4 shows the output signal vs. external magnetic field transfer curve of HFM2905 in DC mode, with Gain = 1 and FS = 1.6 MHz, over the range (-3, +3) Gs, exhibiting excellent linearity. The output voltage at H = 0, i.e., the V_{OFFSET} value, can be adjusted via the SO output zeroing knob.

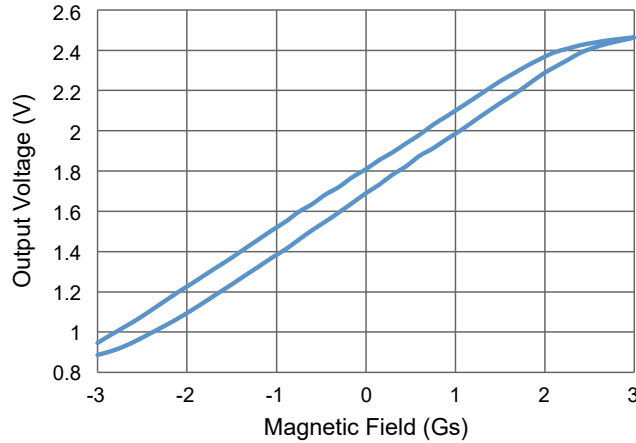

Figure 4. Output Voltage vs. Magnetic Field Hysteresis Loop (G = 1, FS = 1.6 MHz, DC)

6. Amplitude-Frequency Response

Figure 5 shows the spectrum curves of the HFM2905 output signal at 0.1 Gs, Gain = 20, with cutoff settings FS = 1 kHz, FS = 100 kHz, and FS = 1.6 MHz, in both DC mode and AC mode.

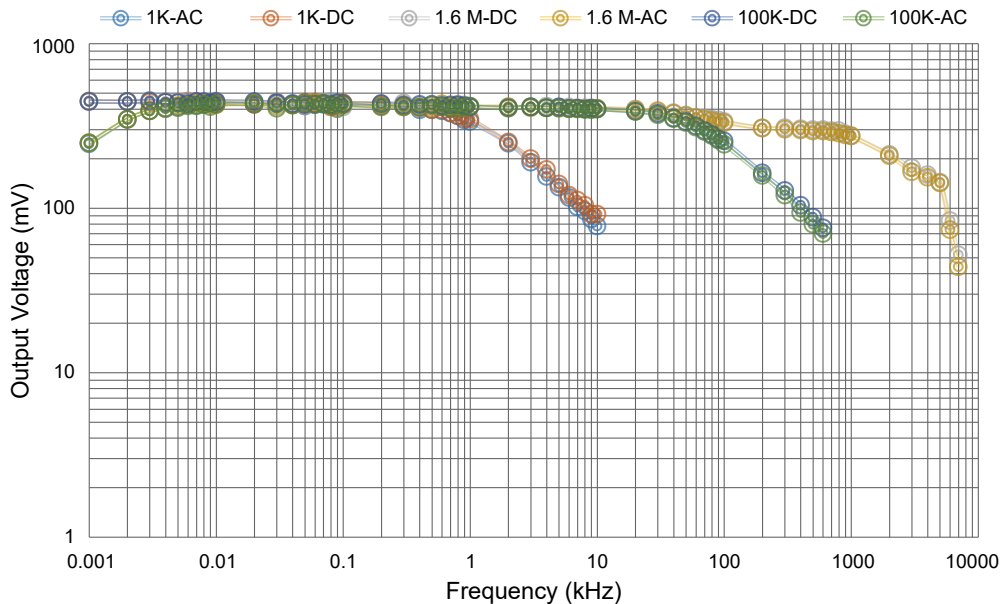

Figure 5. Output Amplitude vs. Frequency (G = 20; cutoff at 1 kHz / 100 kHz / 1.6 MHz)

7. Magnetometer Zero Adjustment

Zero adjustment of the HFM2905 includes TMR offset (TO knob) and output signal zeroing (SO knob). TMR zeroing is performed at the factory. During use, TO typically does not need adjustment; however, environmental factors may cause TMR zero drift, leading to measurement errors and requiring re-zeroing.

Zeroing procedure:

- 1). Insert the probe into a zero-field shielding cylinder to obtain a zero magnetic field. Power the unit via USB, and connect the BNC port to the oscilloscope input.
- 2). Set the AC/DC switch to DC.
- 3). Set Gain = 1.
- 4). Adjust the SO knob so the oscilloscope output reads 0 V.
- 5). Set Gain = 20.
- 6). Adjust the TO knob so the oscilloscope output reads 0 V.
- 7). Repeat steps 3) ~ 6) until the oscilloscope output is 0 V at both Gain = 1 and Gain = 20.
- 8). The resulting TO knob position is the TMR zero point, and the SO knob position is the output signal zero point.

Note: When the probe is removed from the zero-field shielding cylinder, the oscilloscope output will deviate from zero, corresponding to the ambient magnetic field signal.

8. Magnetometer Calibration

Figure 6 shows the calibration fixture setup. The HFM2905 calibration fixture includes two BNC ports:

- The pink BNC cable is the calibration signal input port, connected to the signal generator output.
- The black BNC cable is the calibration signal monitor port, connected to the oscilloscope input.

Insert the HFM2905 probe into the calibration fixture, placing the sensor chip on the stripe surface of the PCB inside the fixture.



Figure 6. Calibration Fixture Setup

Figure 7 shows the PCB inside the calibration fixture:

1. TMR probe position
2. High-frequency current stripline
3. Current sensor CT
4. Calibration signal input port
5. Calibration signal monitor port
6. 50 Ω resistor in series with stripline 2

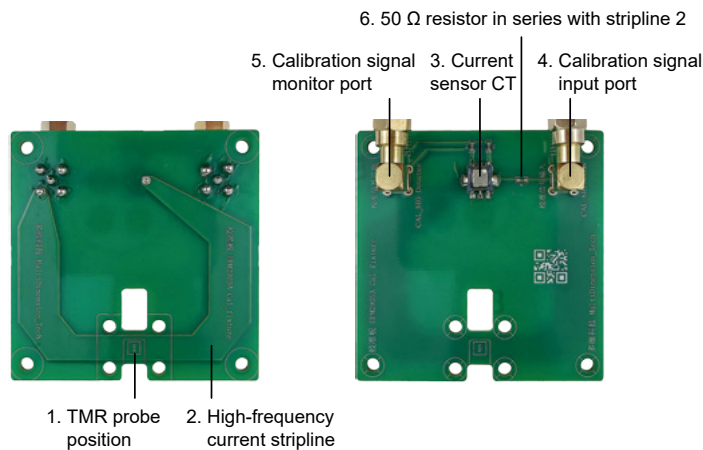

Figure 7. Calibration PCB

Calibration Method 1:

- 1) Insert the HFM2905 probe into the calibration fixture. Power the magnetometer via USB. Connect the magnetometer signal output to the signal generator input. Connect the calibration fixture calibration input port to the signal generator output, and connect the calibration monitor port to the oscilloscope input.
- 2) Set HFM2905 to DC mode.
- 3) Set the signal generator output to square wave, frequency 10 kHz or 1 kHz, duty cycle 50%, low level 0 V, high level 5V.
- 4) Observe the magnetometer output on the oscilloscope: adjust the SO knob so that the output pulse low level is 0 V, and measure the high-level output voltage V_{CAL} .

5) Calibration factor: $K_{CAL} = 0.1 \text{ (Gs)} / V_{CAL} \text{ (mV)}$.

6) For any measured AC signal on HFM2905: $V = V_M \times \sin(2\pi ft)$, the corresponding magnetic-field signal is:
 $H = V_M \times K_{CAL} \times \sin(2\pi ft)$.

Calibration Method 2:

- 1) Signal generator output source: $V_{EX} = 2.5V \times \sin(2\pi ft)$
- 2) HFM2905 output: $V_{OUT} = V_M(f) \times \sin(2\pi ft)$
- 3) Calibration factor: $K_{CAL}(f) = 0.05 \text{ (Gs)} / V_M(f)$

CT Current Sensor Calibration:

Figure 8 shows the CT current sensor operating principle. Current transformer T1 converts the AC current component I_{AC} through the microstrip into a voltage, which then flows through resistors R3 (100 Ω) and R2 (25 Ω). The output V_{OUT} is taken across R2, enabling measurement of I_{AC} .

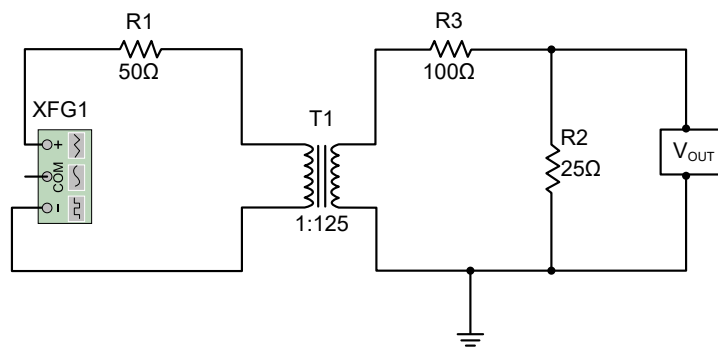

Figure 8. CT Current Sensor Principle

Figure 9 shows the CT conversion factor K_{CT} vs. frequency for different signal generator voltage amplitudes (2000 mV, 2500 mV, 3000 mV, 4000 mV, 5000 mV). K_{CT} varies between 4.6 and 5.0.

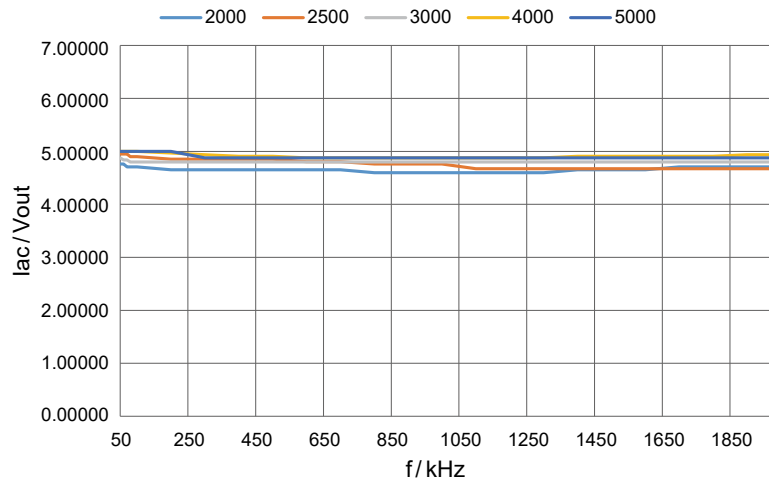

Figure 9. CT Conversion Factor vs. Frequency ($K_{CT} = I_{AC} / V_{OUT}$)

Thus, calibrate the current using CT, then calibrate magnetic field as follows:

- 1) Measure CT output on the oscilloscope: $V_T = V_{CT} \times \sin(2\pi ft)$
- 2) Convert to current: $I_{AC} = V_{CT} \times K_{CT}$
- 3) Current-to-field calibration factor: $B_{CT} = 0.1Gs / 100mA$
- 4) CT-based magnetic-field calibration factor: $K_{CAL} = K_{CT} \times B_{CT}$

9. Applications

Figure 10 shows HFM2905 testing a high-frequency current. In Figure 10-1: 1 is a stripline, such as a PCB trace, carrying high-frequency current; current flows along the axial direction of stripline 1. During measurement, set the axis of probe 3 perpendicular to the axis of stripline 1, with sensor chip 2 positioned at the center of the stripline 1. Connect USB power cable 5 to the USB power supply 6 (or power via a USB adapter using Type-C). Connect BNC cable 7 to oscilloscope 8. Adjust the controls on panel 4 to perform current magnetic-field testing on the microstrip.

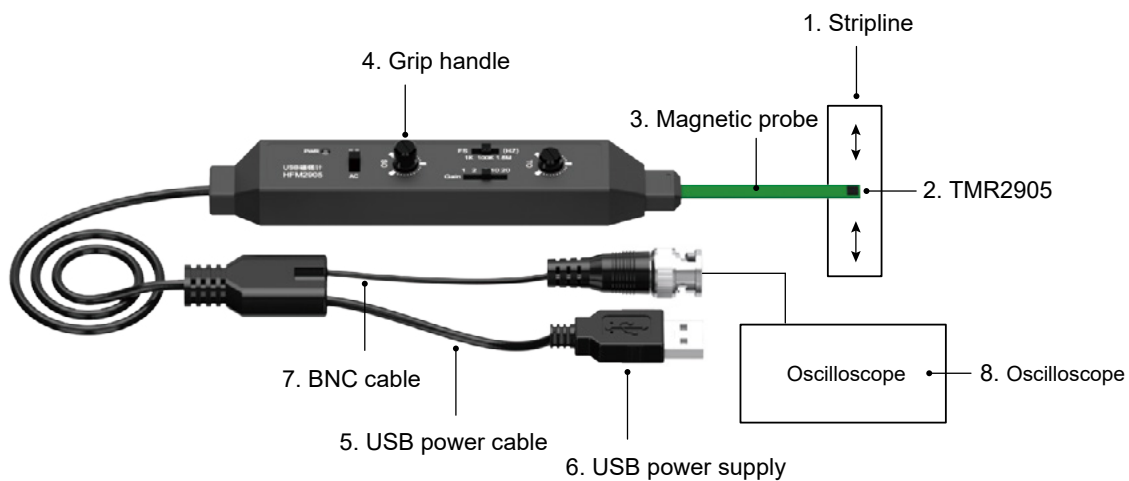

Figure 10-1. High-Frequency Current Measurement (Oscilloscope)

Figure 10-2 shows an equivalent measurement method: connect the BNC output 7 to an AnalogMax DAQ 9, connect DAQ 9 to a computer 10, and use software to measure the stripline current magnetic field.

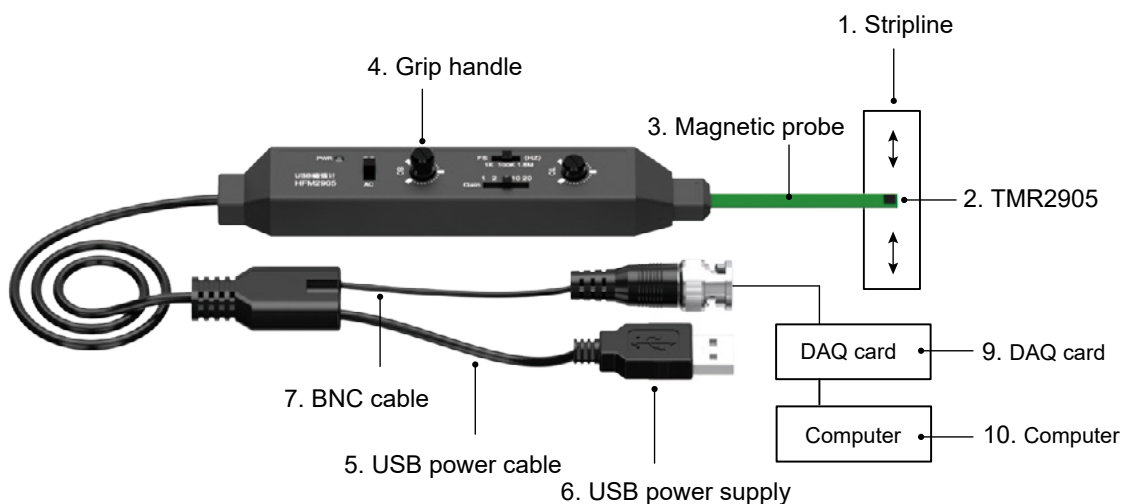

Figure 10-2. High-Frequency Current Measurement (DAQ)

10. Dimensions

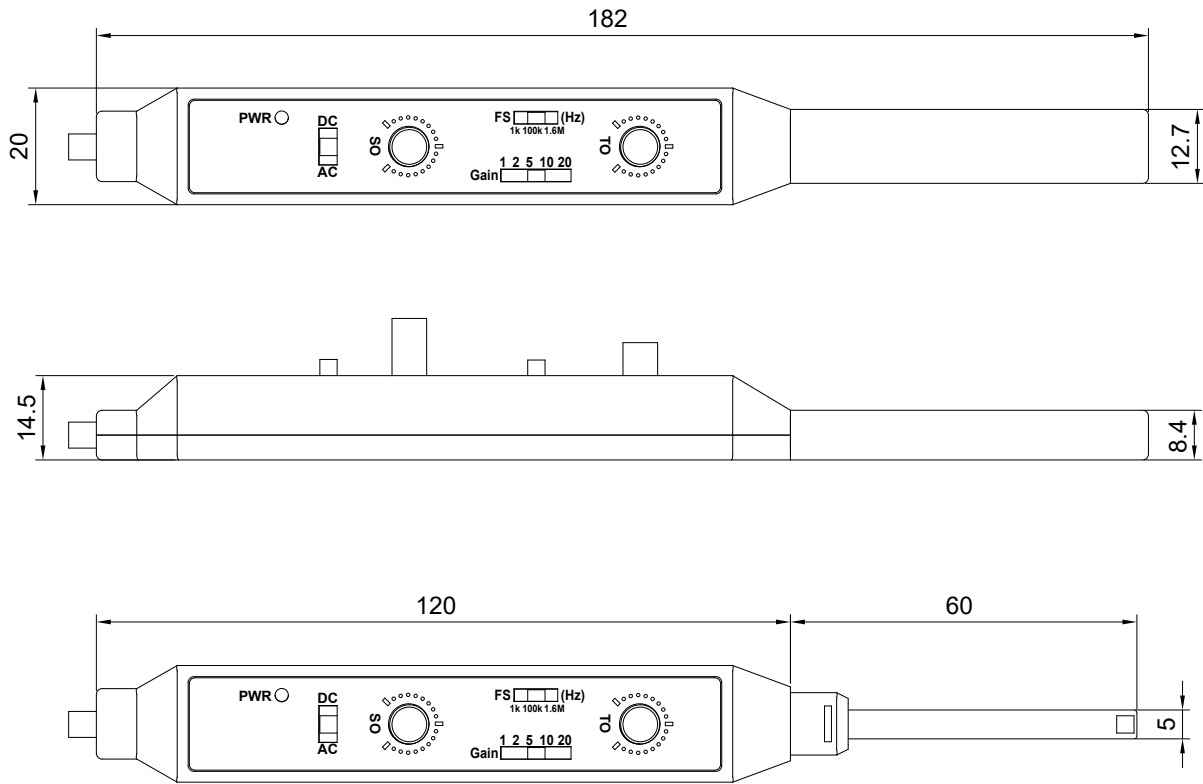

Figure 11. HFM2905 Mechanical Dimensions (Unit: mm)

Copyright © 2026 by MultiDimension Technology Co., Ltd.

Information furnished herein by MultiDimension Technology Co., Ltd. (hereinafter MDT) is believed to be accurate and reliable. However, MDT disclaims any and all warranties and liabilities of any kind, with respect to any examples, hints or any performance or use of technical data as described herein and/or any information regarding the application of the product, including without limitation warranties of non-infringement of intellectual property rights of any third party. This document neither conveys nor implies any license under patent or other industrial or intellectual property rights. Customer or any third-party must further determine the suitability of the MDT products for its applications to avoid the applications default of customer or third-party. MDT accept no liability in this respect.

MDT does not assume any liabilities of any indirect, incidental, punitive, special or consequential damages (including without limitation of lost profits, lost savings, business interruption, costs related to the removal or replacement of any products or rework charges) whether or not such damages are based on tort (including negligence), warranty, breach of contract or any other legal theory. Notwithstanding any damages that customer might incur for any reason whatsoever, MDT's aggregate and cumulative liability towards customer for the products described herein shall be limited in accordance with the terms and conditions of commercial sale of MDT.

Absolute maximum ratings are the extreme limits the device will withstand without damage to the MDT product. However, the electrical and mechanical characteristics are not guaranteed as the maximum limits (above recommended operating conditions) are approached. MDT disclaims any and all warranties and liabilities of the MDT product will operate at absolute maximum ratings.

Specifications may change without notice.

Please download latest document from our official website www.dowaytech.com/en.

Recycling

The product(s) in this document should be disposed of at the end of the product(s) life using a qualified waste management company for recycling in accordance with local regulations.



No.2 Guangdong Road, Zhangjiang Free Trade Zone, Jiangsu, China

Web: www.dowaytech.com/en E-mail: info@dowaytech.com

