

# TMR7554-B

## Board Mounted, Precision Current Sensor

### Description

TMR7554-B is a close loop current sensor for accurate measurement of DC, AC, pulsed current and arbitrary waveform current with galvanic isolation between primary and secondary circuits.



### Features and Benefits

- High accuracy
- Excellent linearity
- Ultra low temperature coefficient
- Fast response time
- Galvanic isolation
- High immunity to external interference
- High immunity to common mode interference
- RoHS & REACH compliant

### Applications

- DC motor drives
- Inverter and variable frequency drives (VFD)
- Uninterruptible power supplies (UPS)
- Power supplies for welding application
- Battery monitoring System

### Selection Guide

Part Number	Primary Nominal Current	Primary Current Measuring Range
TMR7554-010MB	10 mA	±14 mA

### Insulation and Environmental Characteristics

Parameters	Symbol	Typ.	Unit
Dielectric Strength	$V_D$	2.5	kV(50 Hz, 1 min)
Insulation Resistance	$R_{IS}$	1000	$M\Omega$
Creepage Distance	$d_{CP}$	19.5	mm
Clearance	$d_{CL}$	19.5	mm
Ambient Operating Temperature	$T_A$	-40 to +85	$^{\circ}C$
Ambient Storage Temperature	$T_{STG}$	-40 to +85	$^{\circ}C$
Mass	$m$	22	g

## Catalogue

1. Specifications .....	03
2. Typical Output Characteristics.....	03
3. Parameters Definition and Formula.....	04
4. Application Information .....	05
5. Dimensions .....	06

## 1. Specifications

$T_A = +25\text{ }^\circ\text{C}$ ,  $V_{CC} = \pm 15\text{ V}$ ,  $R_M = 100\ \Omega$ , unless otherwise noted

Parameter	Symbol	Condition	Min.	Typ.	Max.	Unit
General Electrical Data						
Primary Nominal Current	$I_{PN}$	TMR7554-010MB	-	10	-	mA
Primary Current Measuring Range	$I_{PM}$	TMR7554-010MB	-14	-	14	mA
Sensitivity	S	$I_P = 0 \sim \pm I_{PN}$	-	2.5	-	mA/mA
Turn Ratio	$K_N$	-	-	2500:1000	-	-
Output Current	$I_{OUT}$	$I_P = 0 \sim \pm I_{PM}$	-	$I_{OE} + S \times I_P$	-	mA
Supply Voltage	$V_{CC}$	$\pm 5\%$	$\pm 12$	$\pm 15$	$\pm 16$	V
Current Consumption	$I_C$	$I_P = 0$	-	$\pm 10$	-	mA
Secondary Coil Resistance	$R_S$	$T_A = +25\text{ }^\circ\text{C}$	-	-	45	$\Omega$
Measuring Resistance	$R_M$	$V_{CC} = \pm 12\text{V}$ , $I_P \leq 10\text{mA}$	30	-	190	$\Omega$
		$V_{CC} = \pm 12\text{V}$ , $I_P \leq 14\text{mA}$	30	-	100	
		$V_{CC} = \pm 15\text{V}$ , $I_P \leq 10\text{mA}$	100	-	350	
		$V_{CC} = \pm 15\text{V}$ , $I_P \leq 14\text{mA}$	100	-	190	
Static Performance Data						
Accuracy	$X_G$	$T_A = +25\text{ }^\circ\text{C}$ , $I_P = 0$ to $\pm I_{PN}$	-0.8	$\pm 0.5$	0.8	% $I_{PN}$
		$T_A = -40\text{ }^\circ\text{C}$ to $+85\text{ }^\circ\text{C}$ , $I_P = 0$ to $\pm I_{PN}$	-1.5	$\pm 1$	1.5	
Linearity Error	$\epsilon_L$	$T_A = -40\text{ }^\circ\text{C}$ to $+85\text{ }^\circ\text{C}$ , $I_P = 0$ to $\pm I_{PN}$	-	$\pm 0.2$	-	% $I_{PN}$
Sensitivity Error	$\epsilon_S$	$T_A = -40\text{ }^\circ\text{C}$ to $+85\text{ }^\circ\text{C}$ , $I_P = 0$ to $\pm I_{PN}$	-	$\pm 0.4$	-	%
Offset Error	$I_{OE}$	$T_A = +25\text{ }^\circ\text{C}$ , $I_P = 0$	-0.15	$\pm 0.1$	0.15	mA
Hysteresis	$I_{OH}$	$I_P = \pm I_{PN} \rightarrow 0$	-0.2	-	0.2	mA
Dynamic Performance Data						
Response Time	$t_R$	$di/dt > 50\text{ A}/\mu\text{s}$ , 10% to 90% of $I_{PN}$	-	-	40	$\mu\text{s}$
Bandwidth	BW	-3 dB	DC	-	150	kHz

## 2. Typical Output Characteristics

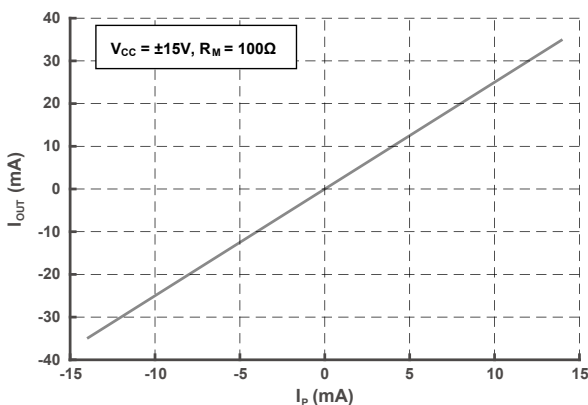

Figure 1. Output Voltage vs Primary Current

### 3. Parameters Definition and Formula

#### 1) Output Current

$$I_{OUT} = I_{OE} + S \times I_P$$

$I_{OUT}$  stands for current sensor output current at given primary current,  $I_{OE}$  stands for offset error,  $S$  stands for sensitivity,  $I_P$  stands for primary current.

#### 2) Accuracy

$$X_G = \text{MAX}_{I_P \in [-I_{PN}, I_{PN}]} \left( \frac{I_{OUT} - (S \times I_P)}{S \times I_{PN}} \times 100\% \right)$$

$I_{PN}$  stands for nominal primary current.

#### 3) Sensitivity

$$S = \frac{I_{OUT(@ I_{PN})} - I_{OUT(@ -I_{PN})}}{2 \times I_{PN}}$$

$I_{OUT(@ I_{PN})}$  and  $I_{OUT(@ -I_{PN})}$  stand for the current output at  $I_{PN}$  and  $-I_{PN}$  respectively.

#### 4) Linearity

$$\varepsilon_L = \text{MAX}_{I_P \in [-I_{PN}, I_{PN}]} \left( \frac{I_{OUT} - (\bar{I}_{OE} + \bar{S} \times I_P)}{S \times I_{PN}} \times 100\% \right)$$

$\bar{S}$  and  $\bar{I}_{OE}$  stand for the average values of the sensitivity and offset error.

#### 5) Hysteresis

$$I_{OH} = \text{MAX } \Delta H$$

$\Delta H$  is the maximum residual output current between full scale positive and negative nominal current.

## 4. Application Information

### Electrical Connection

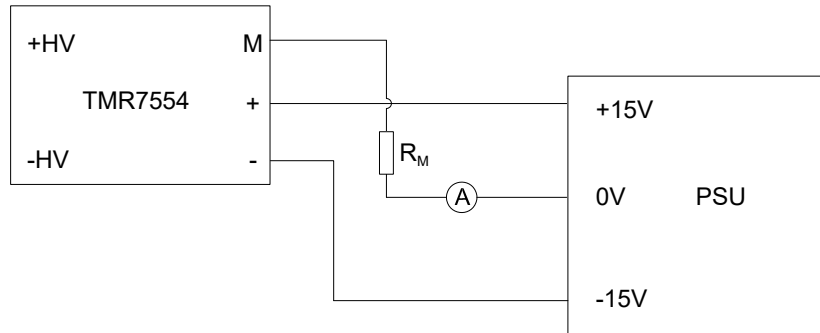

Figure 2. Electrical Connection

### Remarks

1.  $I_{OUT}$  is positive when the primary current ( $I_P$ ) is in the same direction as the arrow indication on the label and vice versa.
2. Improper connection may result in permanent damage of the sensor.
3. Sensor secondary circuitry must be powered prior primary current is being added and when depowering secondary circuitry, primary current must be close to 0A. Improper procedure may result in worse accuracy or result in permanent damage of the sensor.
4. Sensor is customizable upon request.

5. Dimensions

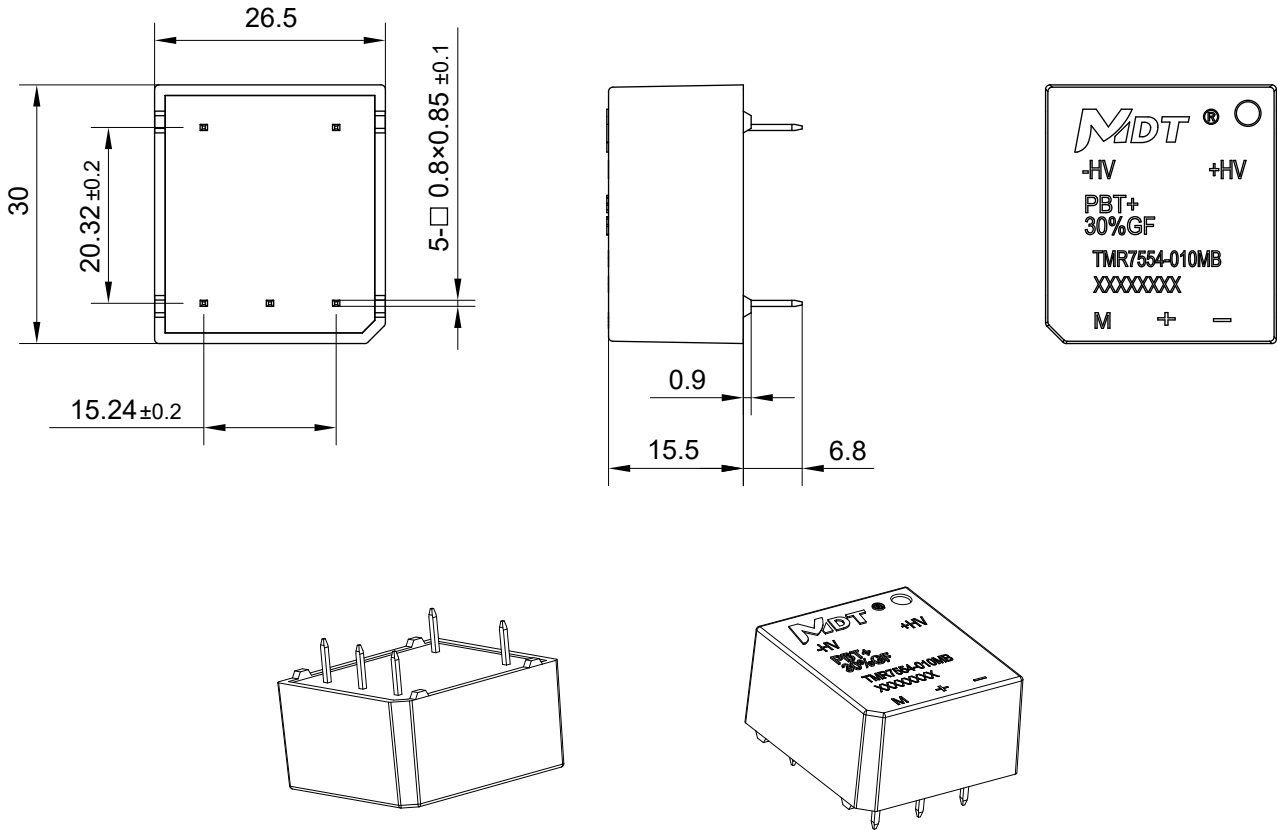

Figure 3. Dimension (unit: mm, tolerances for unmarked scales ±0.5 mm)

Copyright © 2026 by MultiDimension Technology Co., Ltd.

Information furnished herein by MultiDimension Technology Co., Ltd. (hereinafter MDT) is believed to be accurate and reliable. However, MDT disclaims any and all warranties and liabilities of any kind, with respect to any examples, hints or any performance or use of technical data as described herein and/or any information regarding the application of the product, including without limitation warranties of non-infringement of intellectual property rights of any third party. This document neither conveys nor implies any license under patent or other industrial or intellectual property rights. Customer or any third-party must further determine the suitability of the MDT products for its applications to avoid the applications default of customer or third-party. MDT accept no liability in this respect.

MDT does not assume any liabilities of any indirect, incidental, punitive, special or consequential damages (including without limitation of lost profits, lost savings, business interruption, costs related to the removal or replacement of any products or rework charges) whether or not such damages are based on tort (including negligence), warranty, breach of contract or any other legal theory. Notwithstanding any damages that customer might incur for any reason whatsoever, MDT's aggregate and cumulative liability towards customer for the products described herein shall be limited in accordance with the terms and conditions of commercial sale of MDT.

Absolute maximum ratings are the extreme limits the device will withstand without damage to the MDT product. However, the electrical and mechanical characteristics are not guaranteed as the maximum limits (above recommended operating conditions) are approached. MDT disclaims any and all warranties and liabilities of the MDT product will operate at absolute maximum ratings.

Specifications may change without notice.

Please download latest document from our official website [www.dowaytech.com/en](http://www.dowaytech.com/en).

## Recycling

The product(s) in this document should be disposed of at the end of the product(s) life using a qualified waste management company for recycling in accordance with local regulations.



No.2 Guangdong Road, Zhangjiagang Free Trade Zone, Jiangsu, China

Web: [www.dowaytech.com/en](http://www.dowaytech.com/en) E-mail: [info@dowaytech.com](mailto:info@dowaytech.com)

