

TMR3016

High Accuracy Analog TMR Angle Sensor

Description

TMR3016 contains a push-pull Wheatstone bridge, which is composed of four high-sensitivity tunneling magnetoresistance (TMR) elements. The sensor outputs a sinusoidal signal, and the period of this signal corresponds to a 360° rotation of the magnetic field direction within the sensing plane, independent of the externally applied magnetic field strength.

TMR3016 uses a compact DFN4L (0.8 mm × 0.4 mm × 0.23 mm) package for easy assembly in small spaces.

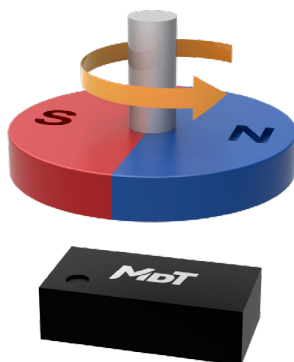
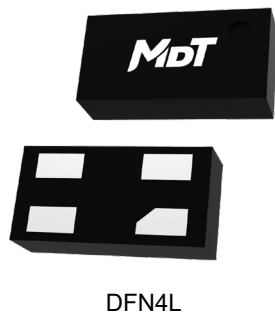

Features and Benefits

- Tunneling magnetoresistance (TMR) technology
- Wide range supply voltage
- Analog differential output
- Excellent temperature stability
- Adapt to large air gap
- Compact DFN package
- RoHS and REACH compliant

Applications

- Angular position sensing
- Linear position sensing

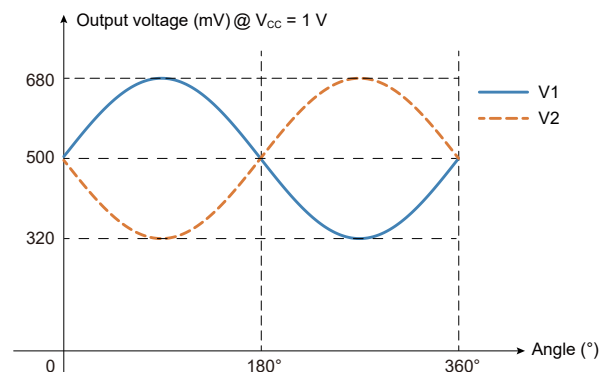

Selection Guide

Part Number	Output	Supply Voltage	Operating Temperature	Package	Packing Form
TMR3016D	Analog	≤ 5.5 V	-30 °C to 85°C	DFN4L	Tape & Reel

Catalogue

1. Functional Block Diagram.....	03
2. Pin Configuration.....	03
3. Absolute Maximum Ratings.....	04
4. Electrical Specifications.....	04
5. Magnetic Specifications.....	04
6. Specification Definitions.....	05
7. Applications.....	06
8. Dimensions.....	07

1. Functional Block Diagram

TMR3016 TMR angle sensor integrates a Wheatstone bridge using TMR elements to increase the output amplitude and improve the temperature characteristics.

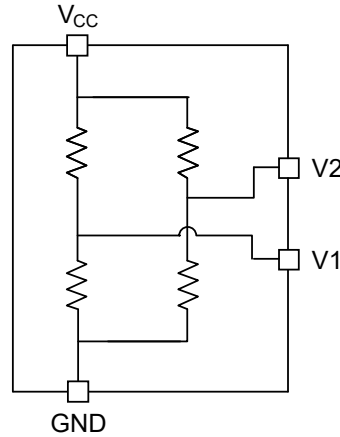

Figure 1. Block diagram

2. Pin Configuration

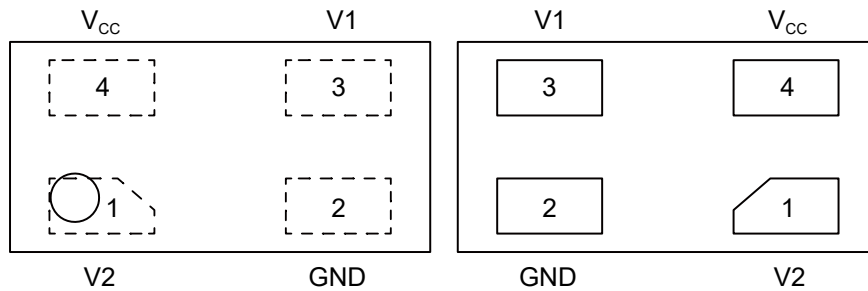

Figure 2. Pin configuration (DFN4L)

Number	Name	Function
1	V2	Differential Analog Output signal 2
2	GND	GND
3	V1	Differential Analog Output signal 1
4	V _{CC}	Power supply

3. Absolute Maximum Ratings

Parameters	Symbol	Min.	Max.	Unit
Supply voltage	V_{CC}	-	6	V
Magnetic flux density	B	-	3000	Gs
ESD performance (HBM)	$V_{ESD(HBM)}$	-	3000	V
ESD performance (CDM)	$V_{ESD(CDM)}$	-	2000	V
Operating ambient temperature	T_A	-30	85	°C
Storage ambient temperature	T_{STG}	-40	125	°C

Note: The absolute maximum rating only lists the conditions under which the sensors are not permanently damaged. For normal operations please refer to Specifications.

4. Electrical Specifications

$V_{CC} = 1.0\text{ V}$, $T_A = 25\text{ °C}$

Parameter	Symbol	Condition	Min.	Typ.	Max.	Unit
Supply voltage	V_{CC}	operating	-	-	5.5	V
Bridge resistance	R_B	$B = 300\text{ Gs}$, field direction=0°	1	2.5	4	kΩ
Peak voltage	V_{PEAK}	$B = 300\text{ Gs}$	140	180	220	mV/V
Midpoint voltage	V_{Mid}	$B = 300\text{ Gs}$	450	500	550	mV/V
Offset voltage	V_{OFFSET}	$B = 300\text{ Gs}$	-15	0	15	mV/V
Temperature coefficient of bridge resistance	TCR_B	-	-	-0.05	-	%/°C
Temperature coefficient of amplitude	TCV_{PEAK}	-	-	-0.09	-	%/°C

5. Magnetic Specifications

Parameter	Symbol	Condition	Min.	Typ.	Max.	Unit
Magnetic flux density	B	-	200	-	800	Gs

Note: 1 Gauss in air = 0.1 millitesla = 79.8 A/m

6. Specification Definitions

6.1 Bridge resistance R_B

Resistance between pin V_{CC} and GND

6.2 Output amplitude V_{PEAK}

$$V_{PEAK1} = \frac{V_{MAX1} - V_{MIN1}}{2} \quad V_{PP1} = V_{MAX1} - V_{MIN1}$$

$$V_{PEAK2} = \frac{V_{MAX2} - V_{MIN2}}{2} \quad V_{PP2} = V_{MAX2} - V_{MIN2}$$

6.3 Midpoint voltage V_{Mid}

$$V_{Mid1} = \frac{V_{MAX1} + V_{MIN1}}{2}$$

$$V_{Mid2} = \frac{V_{MAX2} + V_{MIN2}}{2}$$

6.4 Offset V_{OFFSET}

$$V_{OFFSET} = V_{Mid1} - V_{Mid2}$$

6.5 Temperature coefficient of bridge resistance TCR_B

R_H : High temperature resistance R_L : Low temperature resistance R_N : Resistance at 25°C

T_H : High temperature T_L : Low temperature T_N : 25°C

$$TCR_B = \frac{R_H - R_L}{R_N (T_H - T_L)} \times 100\%$$

6.6 Temperature coefficient of amplitude TCV_{PEAK}

V_{PEAKH1} : V_{OUT1} in high temp V_{PEAKL1} : V_{OUT1} in low temp V_{PEAKN1} : V_{OUT1} at 25°C

V_{PEAKH2} : V_{OUT2} in high temp V_{PEAKL2} : V_{OUT2} in low temp V_{PEAKN2} : V_{OUT2} at 25°C

T_H : High temperature T_L : Low temperature T_N : 25°C

$$TCV_{PEAK1} = \frac{V_{PEAKH1} - V_{PEAKL1}}{V_{PEAKN1} (T_H - T_L)} \times 100\% \quad TCV_{PEAK2} = \frac{V_{PEAKH2} - V_{PEAKL2}}{V_{PEAKN2} (T_H - T_L)} \times 100\%$$

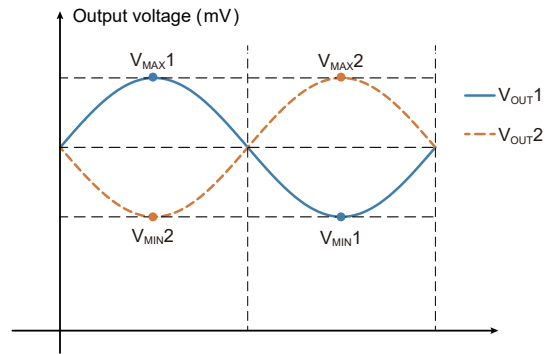

Figure 3. Definition of V_{MIN} and V_{MAX} in output signal

7. Applications

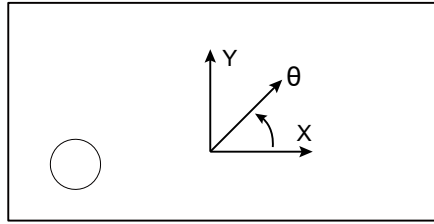

Figure 4. Sensing direction of TMR3016

The sensing direction is parallel to the X-Y plane where package laser mark is located as shown in Figure 4. When the sensor is in an appropriate magnetic field, the resistance value of each TMR element of the sensor changes due to the difference between the sensitive direction of each TMR element and the direction of the magnetic field, resulting in a corresponding change in the output voltage.

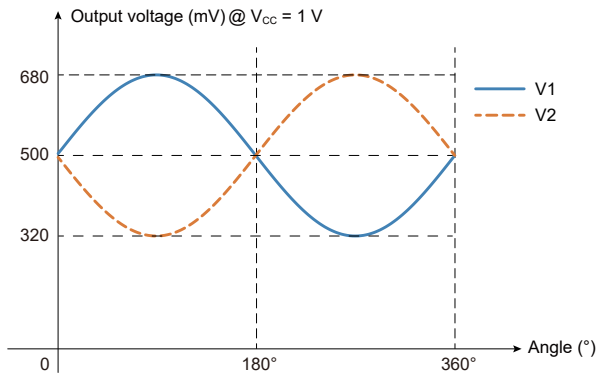

Figure 5. Single-ended output of TMR3016 in one period @ $V_{CC} = 1\text{ V}$

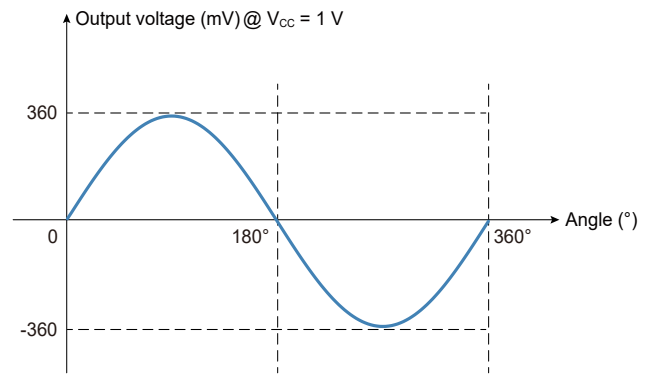

Figure 6. Differential output of TMR3016 in one period @ $V_{CC} = 1\text{ V}$

8. Dimensions

DFN4L Package

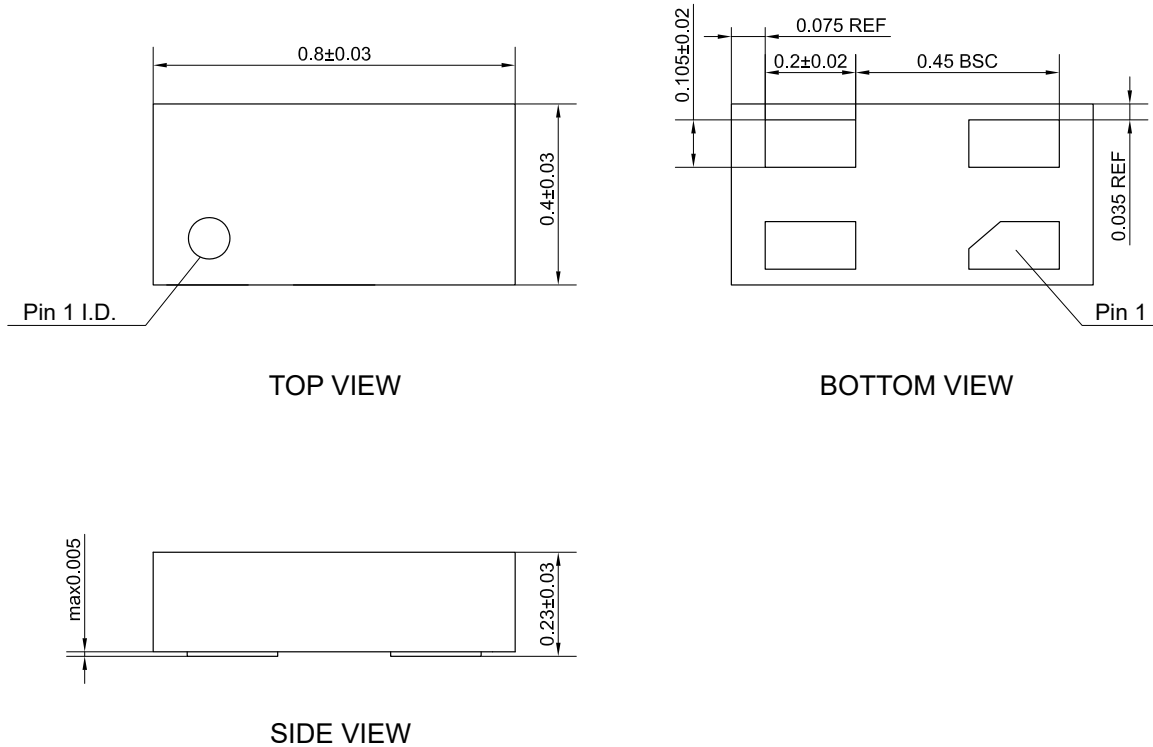

Figure 7. Package outline of DFN4L (unit: mm)

Product Marking Description

“Y” represents the year of material input, with one character for every half year, and 26 characters covering 13 years;

“W” represents the week of material input, with 26 letters representing 26 weeks;

“L” represents the batch of material input, with one character for each wafer per input;

“PN” represents the part number.

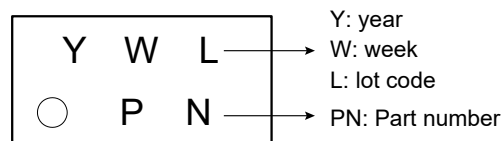

Copyright © 2024 by MultiDimension Technology Co., Ltd.

Information furnished herein by MultiDimension Technology Co., Ltd. (hereinafter MDT) is believed to be accurate and reliable. However, MDT disclaims any and all warranties and liabilities of any kind, with respect to any examples, hints or any performance or use of technical data as described herein and/or any information regarding the application of the product, including without limitation warranties of non-infringement of intellectual property rights of any third party. This document neither conveys nor implies any license under patent or other industrial or intellectual property rights. Customer or any third-party must further determine the suitability of the MDT products for its applications to avoid the applications default of customer or third-party. MDT accept no liability in this respect.

MDT does not assume any liabilities of any indirect, incidental, punitive, special or consequential damages (including without limitation of lost profits, lost savings, business interruption, costs related to the removal or replacement of any products or rework charges) whether or not such damages are based on tort (including negligence), warranty, breach of contract or any other legal theory. Notwithstanding any damages that customer might incur for any reason whatsoever, MDT's aggregate and cumulative liability towards customer for the products described herein shall be limited in accordance with the terms and conditions of commercial sale of MDT.

Absolute maximum ratings are the extreme limits the device will withstand without damage to the MDT product. However, the electrical and mechanical characteristics are not guaranteed as the maximum limits (above recommended operating conditions) are approached. MDT disclaims any and all warranties and liabilities of the MDT product will operate at absolute maximum ratings.

Specifications may change without notice.

Please download latest document from our official website www.dowaytech.com/en.

Recycling

The product(s) in this document need to be handed over to a qualified solid waste management services company for recycling in accordance with relevant regulations on waste classification after the end of the product(s) life.



No.2 Guangdong Road, Zhangjiagang Free Trade Zone, Jiangsu, China

Web: www.dowaytech.com/en E-mail: info@dowaytech.com

